

Carrying Network Resource related Information in IPv6 Extension Header

draft-ietf-6man-enhanced-vpn-vtn-id-14

Jie Dong, Zhenbin Li @Huawei

Chongfeng Xie, Chenhao Ma @China Telecom

Gyan Mishra @Verizon

6MAN IETF 125 Meeting March 2026

Background Recap

- Network Resource Partition (NRP) is a set of network resources allocated on a connected set of links in the underlay network
 - The concept is introduced in RFC 9543
 - An NRP can be used to support one or a group of network slice/enhanced VPN services as described in RFC 9732
- This document introduces a new Hop-by-Hop option to carry Network Resource related information in IPv6 packets
 - Used by transit nodes to determine the NRP a packet belongs to
 - NRP-specific packet processing and forwarding can be performed on each hop
 - This HBH option is extensible for other network resource related semantics and functions
- The latest revision incorporates the comments received during and after IETF 124

Encoding of Network Resource (NR) Option

- A new HBH option for network resource related information
 - The format of the option has been stable
 - There are multiple implementations which prove the viability

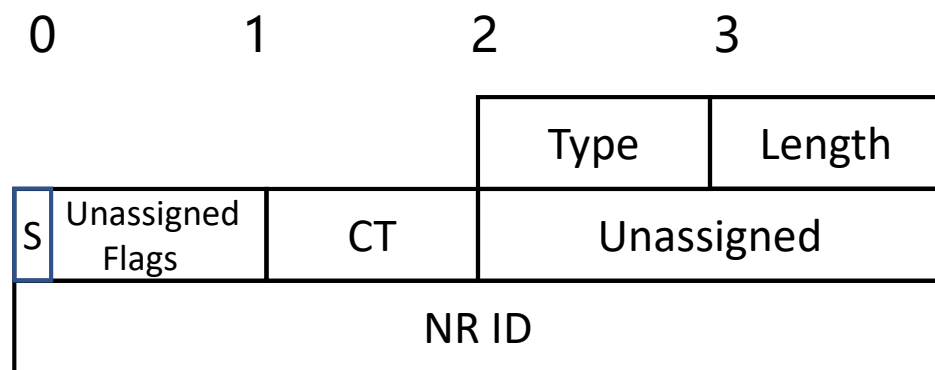

- **Option Type:** TBA
- **Length:** Length of the data fields in octets
- **Flags:** the first bit is defined as Strict Match (S) flag
 - It is used to control the packet forwarding behavior when there is no matched NRP on a transit node
- **Context Type (CT):** Indicates the semantics and length of the NR ID
 - **CT=0:** The ID is a 4-octet network-wide **NRP Selector ID**
- **Unassigned field:** leave for future extension
- **NR ID:** The identifier of a set of network resources

Discussion during and after IETF 124

- Generalization of this Option
 - Due to the limited number of remaining IPv6 HBH/DOH option code points, generalization may be needed in future, and the current encoding leaves room for future extensions
- Length of the NRP Selector ID for IPv6 data plane
 - There was a comment about providing a lightweight encoding (with a shorter NRP Selector ID)
 - Majority of the feedback is to make the ID length 32-bit
 - Provides a single encoding that is enough both for now and for the future
 - If a different encoding is needed in the future
 - Do it in a future document possibly by defining a new Flag or Context Type
- Management of the NRP Selector ID in deployment
 - Provide suggestions about the NRP Selector ID assignment

Updates in version -14

- Add suggestions about NRP Selector ID allocation in deployment
 - The NRP Selector ID is a network-wide unique identifier which needs to be managed by the network operator. To avoid possible conflicts in the assignment and use of NRP Selector IDs, operators are RECOMMENDED to start the allocation of NRP Selector ID from 1, and continue the allocation incrementally in the NRP Selector ID space.

Next Steps

- Request for WG last call
- Code point early allocation has been requested

Thank You