

Dynamic Internet Multicast Tunneling

(draft-zzhang-mboned-dynamic-internet-mcast-
tunnel)

Jeffrey Zhang <zhaohui.zhang@hpe.com>
Lenny Giuliano <leonard.giuliano@hpe.com>
Brad Tarno <brad.tarno@disney.com>
Chris Lenart <chris.lenart@verizon.com>

Why Dynamic Internet Multicast Tunneling?

- Multicast requires every layer 3 hop between sources and receivers to be multicast-enabled
- Overlays/Tunnels overcome this hurdle
 - Static Tunnels (eg, GRE) require manual config of both endpoints, plus routing for RPF
 - Dynamic Tunnels (specifically, AMT) does not support routing protocol traversal (only IGMP)
- CDNs/CPs want zero-conf tunnels (AMT) in “Middle Mile”
 - How can *routers* function as AMT GWs without routing information?
 - How do they know *which relays* can reach *which sources*?

Dynamic Internet Multicast Tunneling

- In BGP route to source, use BGP IP Address-Specific Extended Community (EC) to specify AMT Relay (or UMH)
- AMT Relay (or UMH) encoded in EC must have multicast connectivity (native or tunneled) to the network in the route being advertised
- Can work for other dynamic tunneling options beyond AMT (eg, PIM Light)

AMT- How it works

- Gateway (client) uses Anycast to discover nearest relay.
- UDP-encapped IGMP report is sent to relay at the edge of the mcast network.

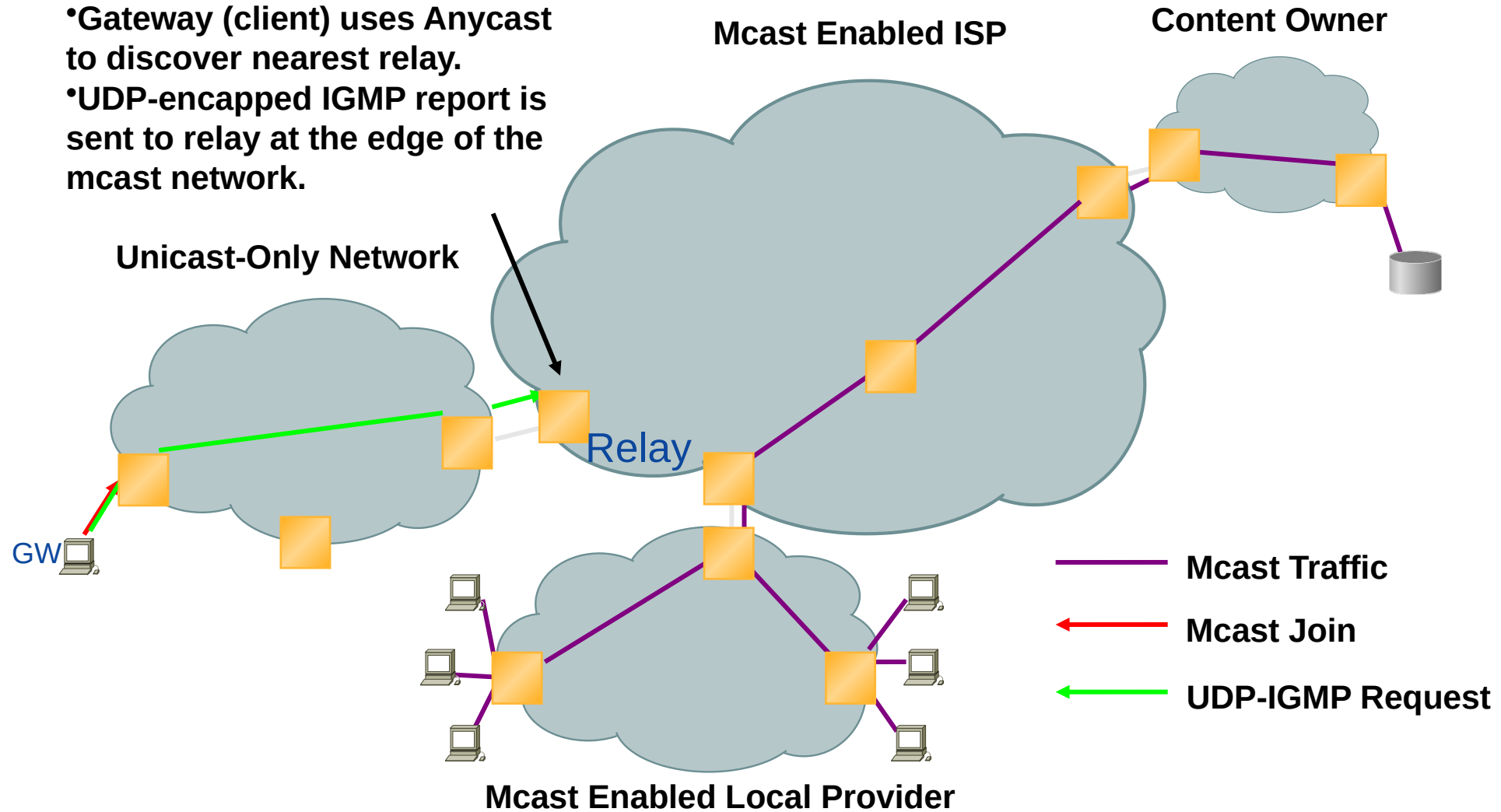

AMT - Unicast Edge Network

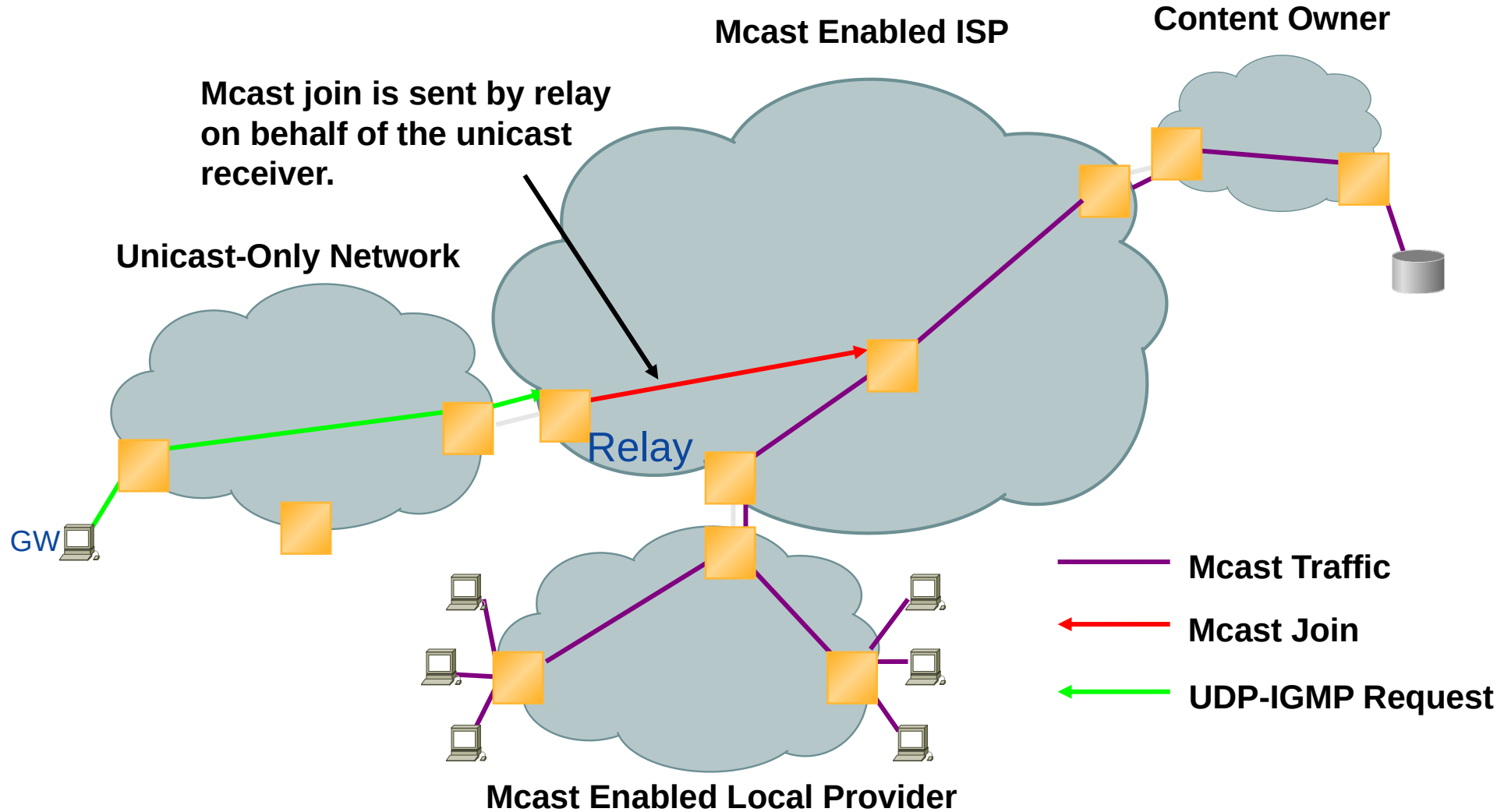

AMT - Unicast Edge Network

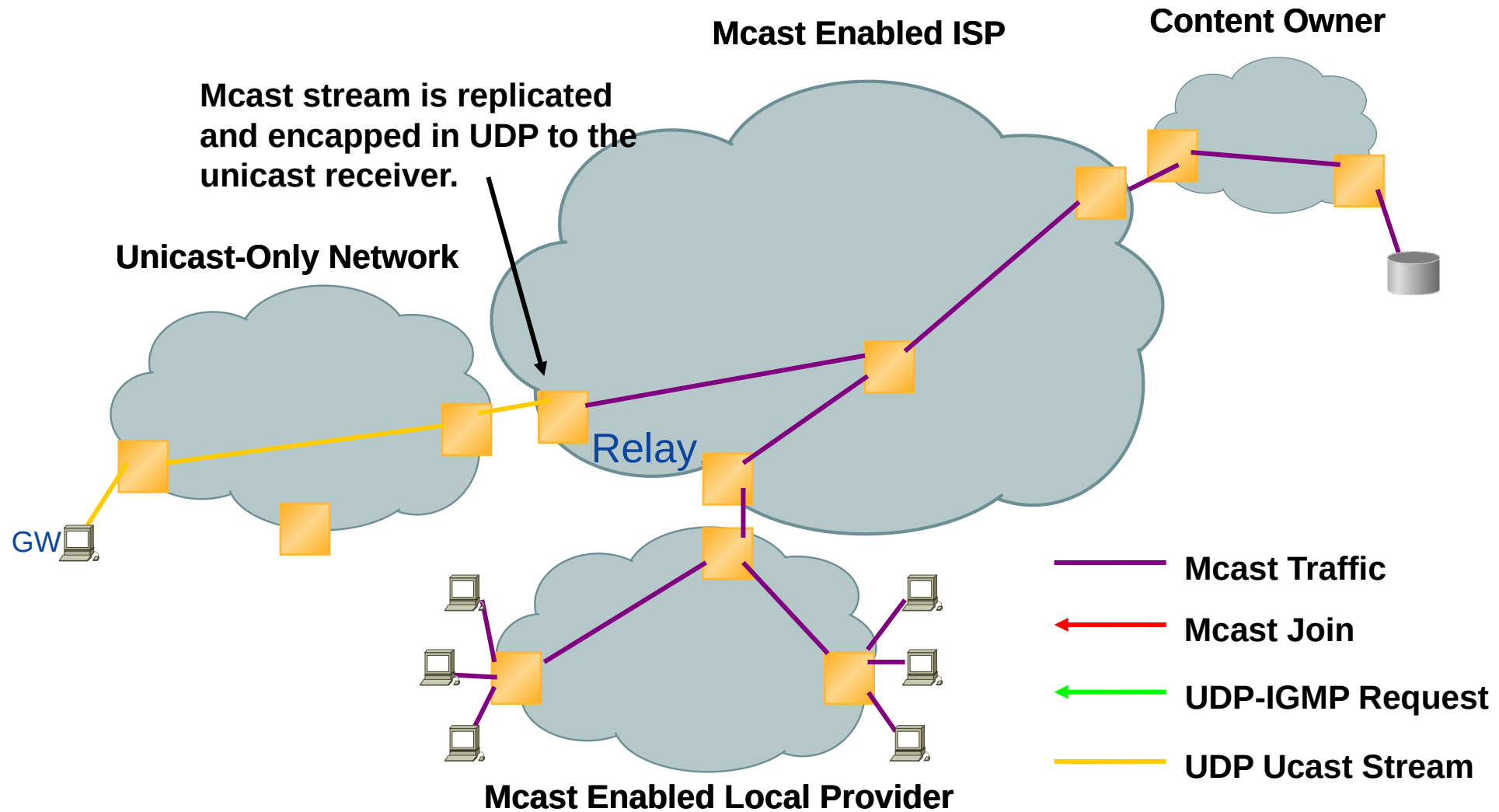

AMT - Unicast Edge Network

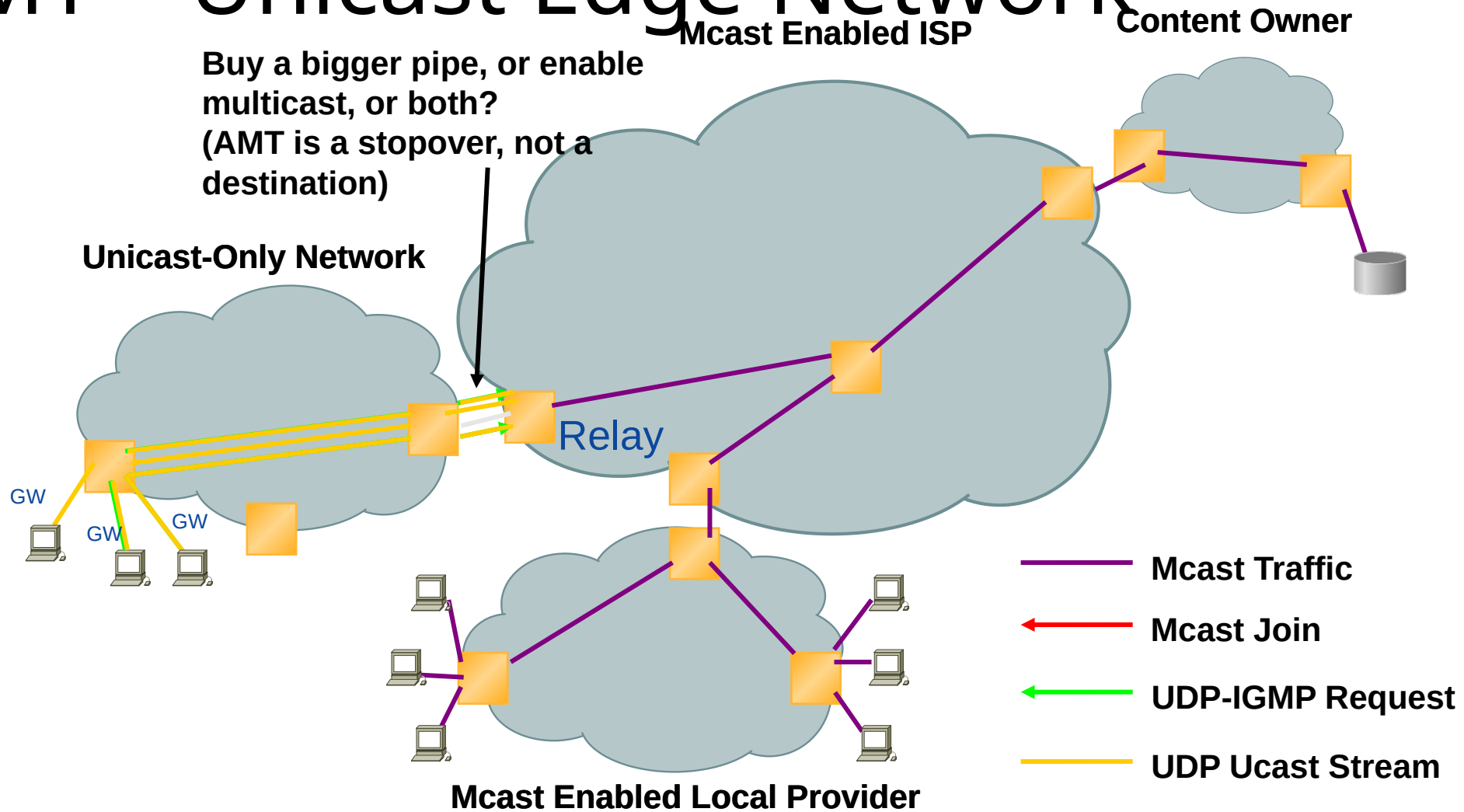

TreeDN (RFC9706) = SSM + AMT

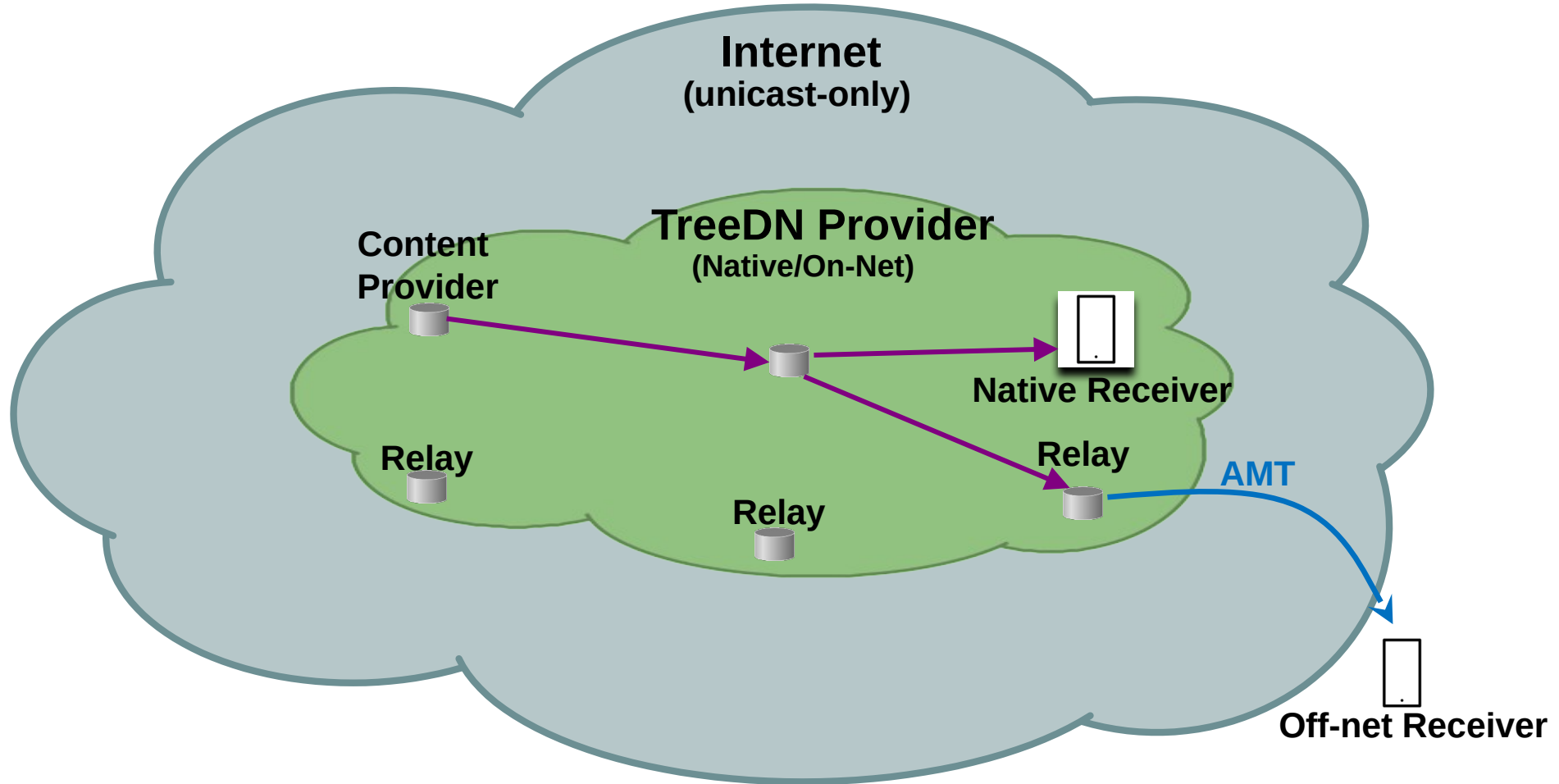

TreeDN *with* Dynamic Multicast Tunneling

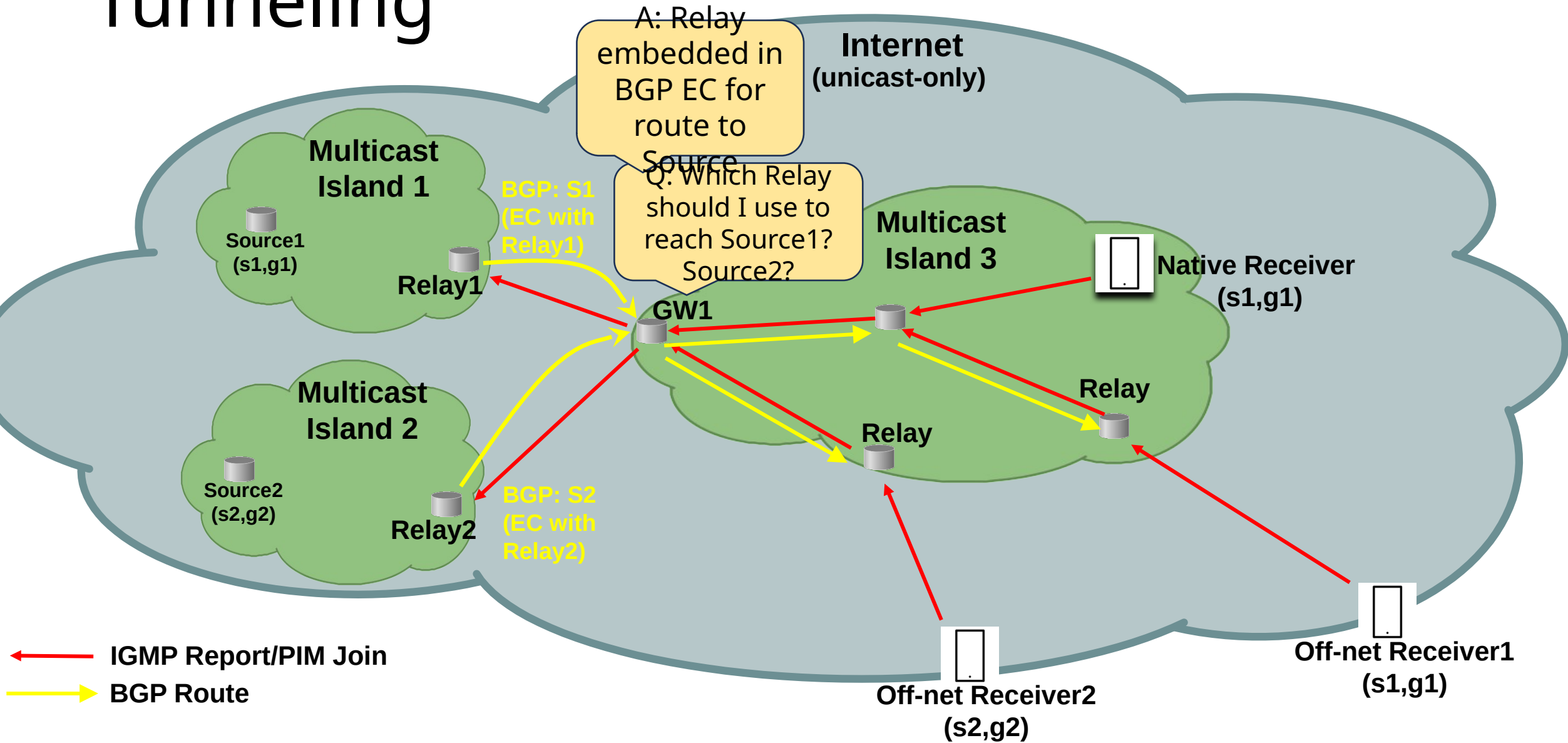

TreeDN *with* Dynamic Multicast Tunneling

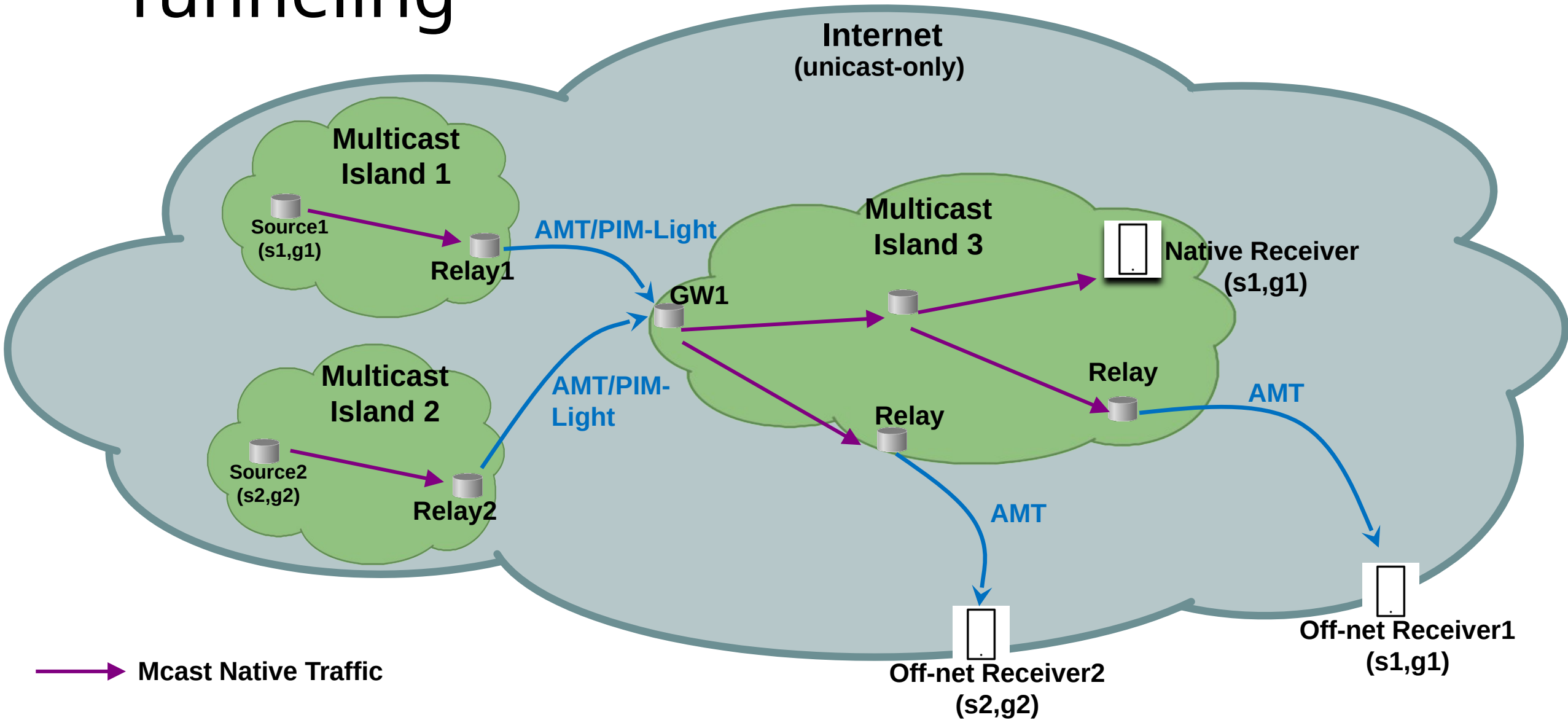

Dynamic Inet Multicast Tunneling Implications

- Flexible architecture, allows core routers to become AMT GWs
 - ...in a world with > 1 AMT relay
- Routers can be *both* AMT GWs and Relays
- Extends TreeDN (RFC9706) to support “Middle Mile” tunneling
 - Previously only *really* covered “Last Mile” tunneling

Use Cases

- CPs/CDNs can originate/transport multicast content that can be received by multicast islands anywhere on the Internet (non-directly connected)
 - Zero-conf mcast tunnels to downstream networks

Next Steps

- Seeking WG adoption in MBONED- this is an AMT Relay Discovery mechanism
- Seeking feedback from MOPS, PIM, IDR, et al