

Public

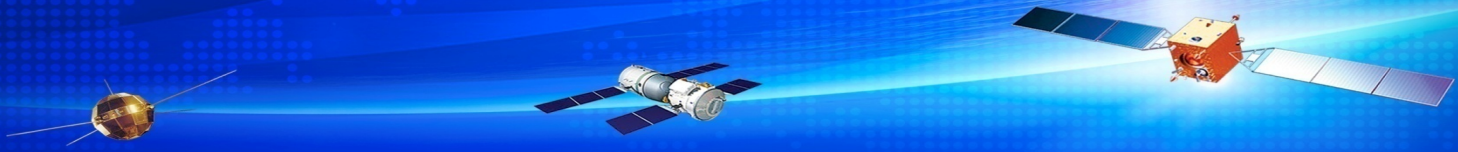

Protocol Architecture of Earth-Moon Integrated Network

Beijing Institute of Spacecraft System Engineering, CAST

SOIS Deputy Area Director, CCSDS

Xiongwen He

2026.3



An illustration of space exploration. At the top, a satellite with solar panels orbits a bright sun. Below it, another satellite is shown. In the foreground, a lunar lander and rover are on the surface of the moon. The background is a deep blue space with light trails.

Catalogue

1

Background Requirements

2

Current Research Status

3

Key Achievements

4

Expected Effect & Prospect

1.1 Overview

In deep space exploration, “CE-4” has landed on the far side of the moon, “CE-5” returned to the earth with soil of the moon. **“CE-6” returned with soil from the far side of the moon.**

“TW-1” visited Mars, accomplished “surrounding, landing and touring ” with one mission. Space Exploration of China has been accomplished **from Earth-Moon scope to interplanetary scope.**



1.1 Overview

In the coming year, China will continue to carry out **Lunar exploration project**, such as high-precision Lunar polar region landing , and construction of International Lunar Research Station(ILRS).

China will continue to carry out planetary exploration project, complete missions like sampling and returning from Mars, exploring the Jupiter scope, and demonstrate plans for exploring the margin of solar system.

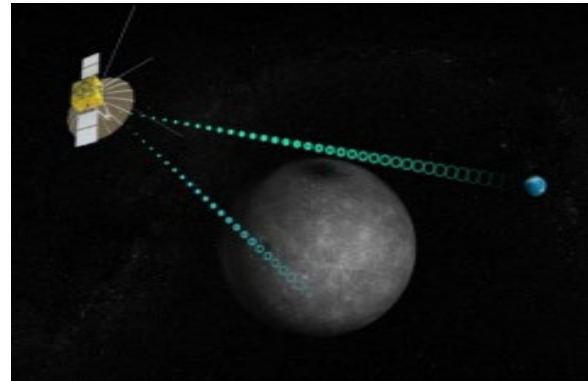
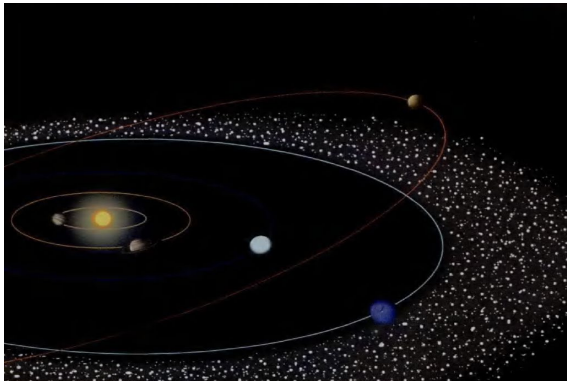

1.1 Overview

Before 2030, China will achieve a manned landing on the moon, and in the long term, it will further promote the development of new industries such as the utilization of in-situ lunar resources.

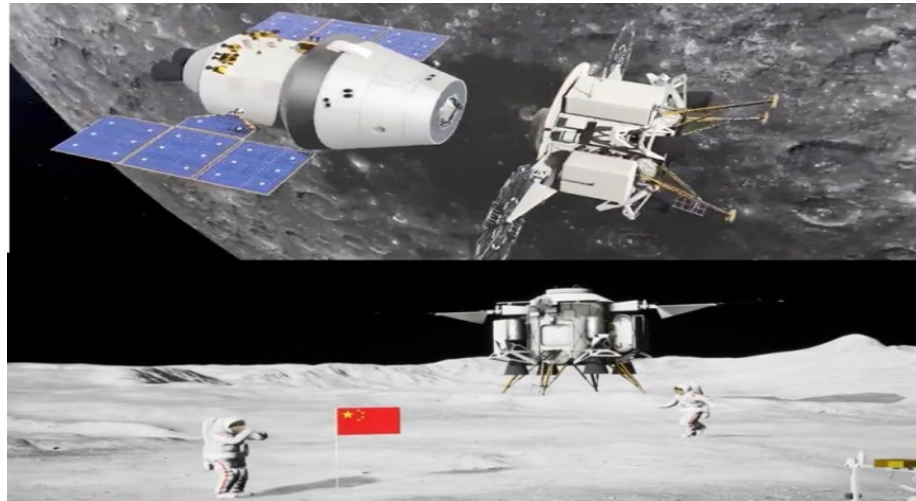

1.2 Requirements

Communication-Navigation-Remote Sensing Requirements for Deep Space Exploration:

- ✓ Efficient network communication
- ✓ Precise PNT
- ✓ Efficient space awareness
- ✓ On-demand information services





Catalogue

1

Background Requirements

2

Current Research Status

3

Key Achievements

4

Expected Effect & Prospect

2.1 CCSDS

● Communication Protocols

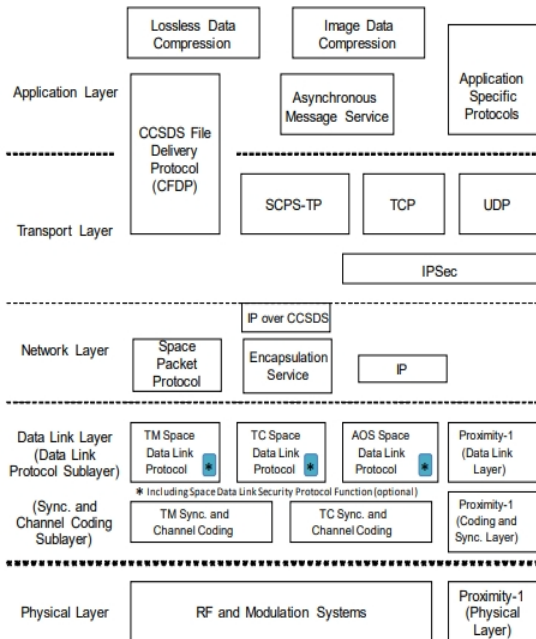

CCSDS 130.0-G-3 2014

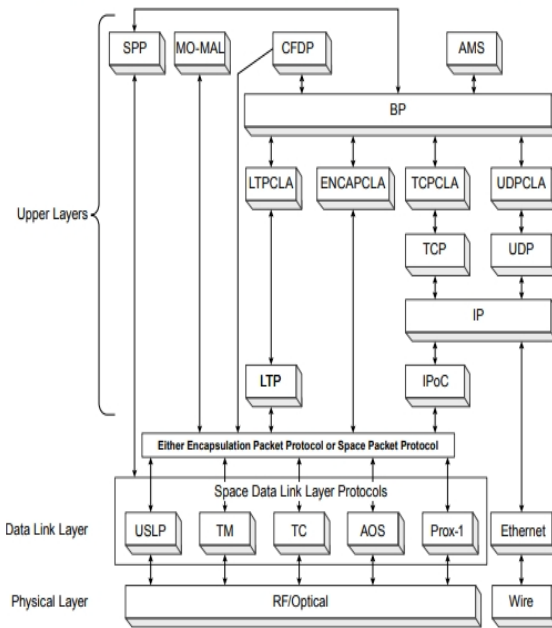

CCSDS 130.0-G-4 2023

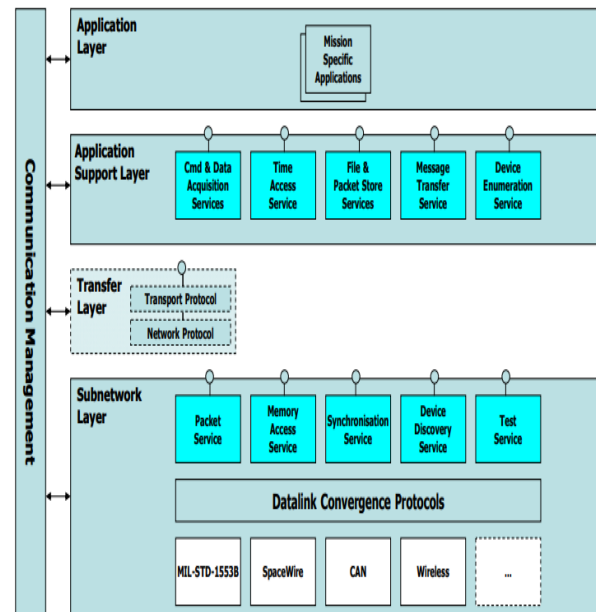

CCSDS 850.0-G-2 2013

2.2 ECSS

ECSS standards include E10 system engineering, E20 electronic and optical engineering, E30 discipline mechanical engineering, E40 software engineering, E50 communication protocols, E60 control engineering and E70 ground systems & operations engineering. E50 and E70 are compatible with CCSDS.

ECSS Standards
Engineering branch

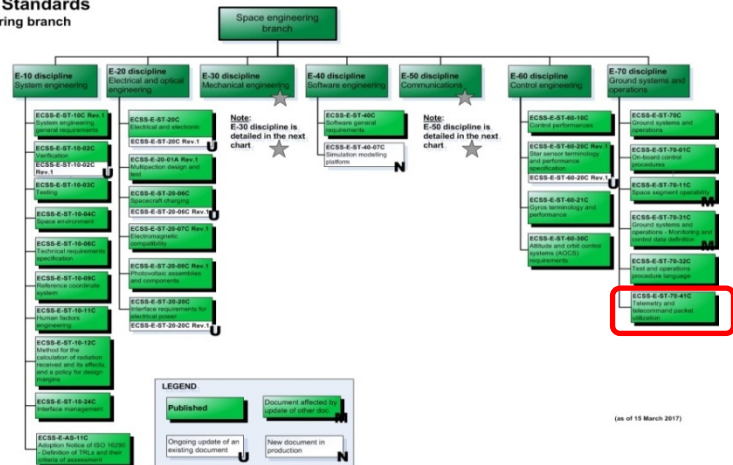

ECSS Standard System

E-50 discipline
Communications

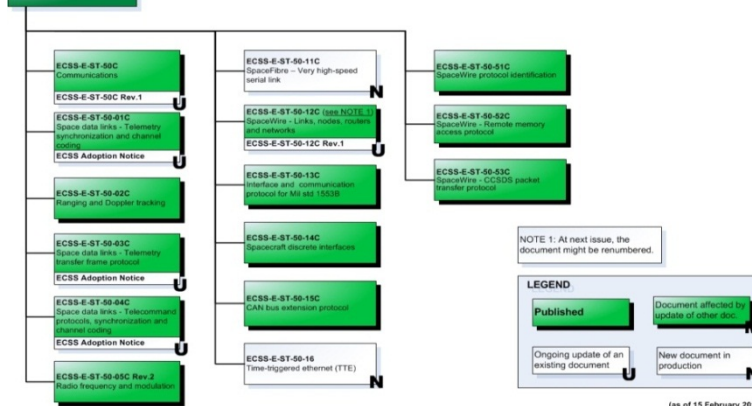

E50 communication standards

2.3 IETF

- The TCP/IP protocol originated in the 1960s and has been widely used in the Internet
- IETF designed the next generation Internet protocol IPv6
- Tsinghua University led the construction of the second generation of IPv6 based China Education and Research Network (**CERNET2**)
- On November 26, 2017, China issued the plan for advancing the deployment of IPv6
- **BP/LTP** also developed

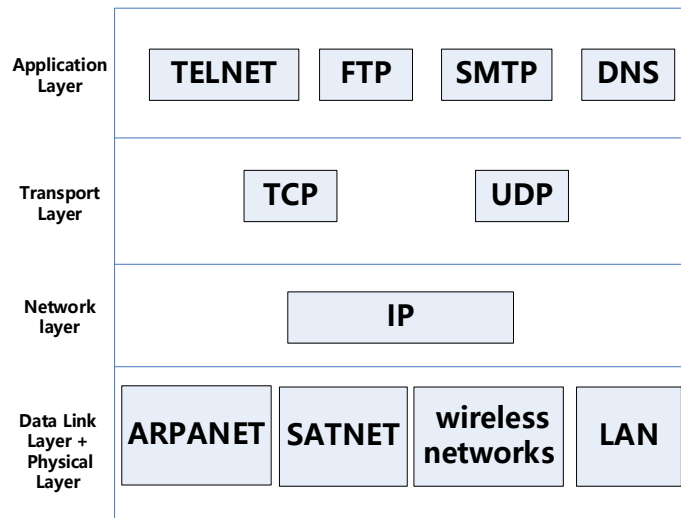

TCP/IP

2.4 Summary

- **Network Development Trend:** to build heterogeneous interconnected Earth-Moon integrated networks
- **Current Protocol Architecture:** Different layering, different protocols, different applications...



Catalogue

1

Background Requirements

2

Current Research Status

3

Key Achievements

4

Expected Effect & Prospect

3 Key Achievements

The CAST project team has achieved a series of results through years of research and spacecraft applications in various fields.

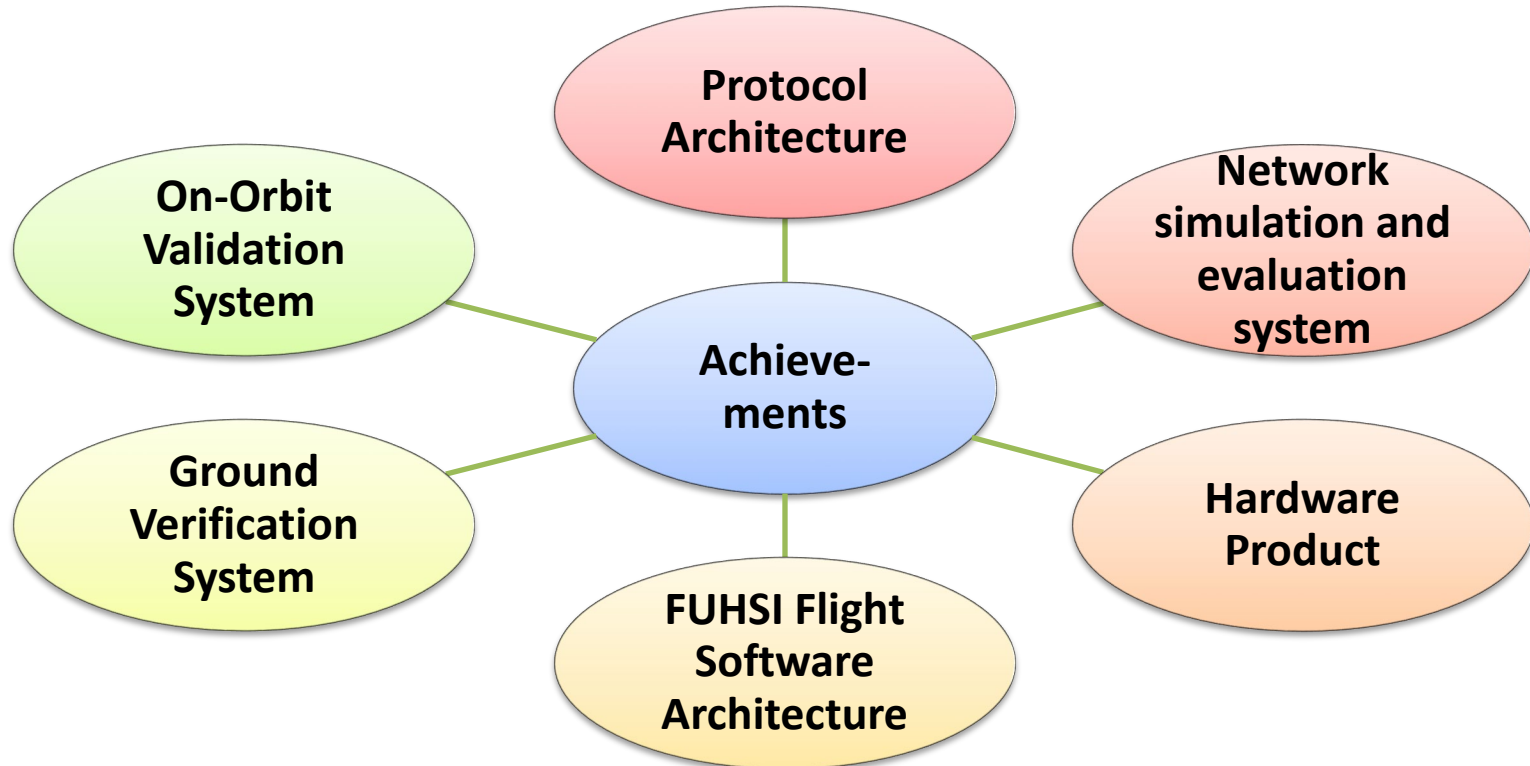

3.1 Protocol Architecture

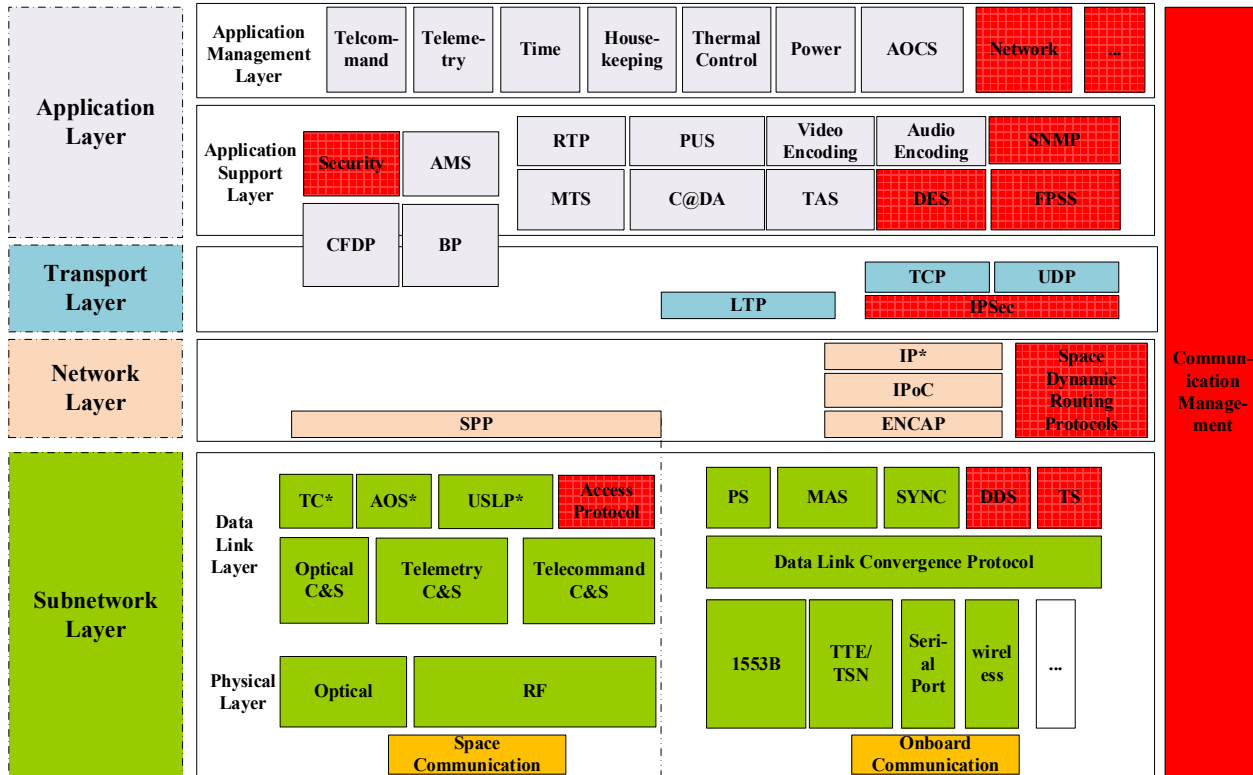

Integrated CCSDS, ECSS, IETF protocols

- ✓ All in one
- ✓ Generalization
- ✓ Layered

* Includes optional security protocols

3.2 Network simulation and evaluation system

We developed a Network simulation and evaluation system, in order to enhance the space network and protocol system design and verification capabilities, with support of Nanjing University and Xidian University .

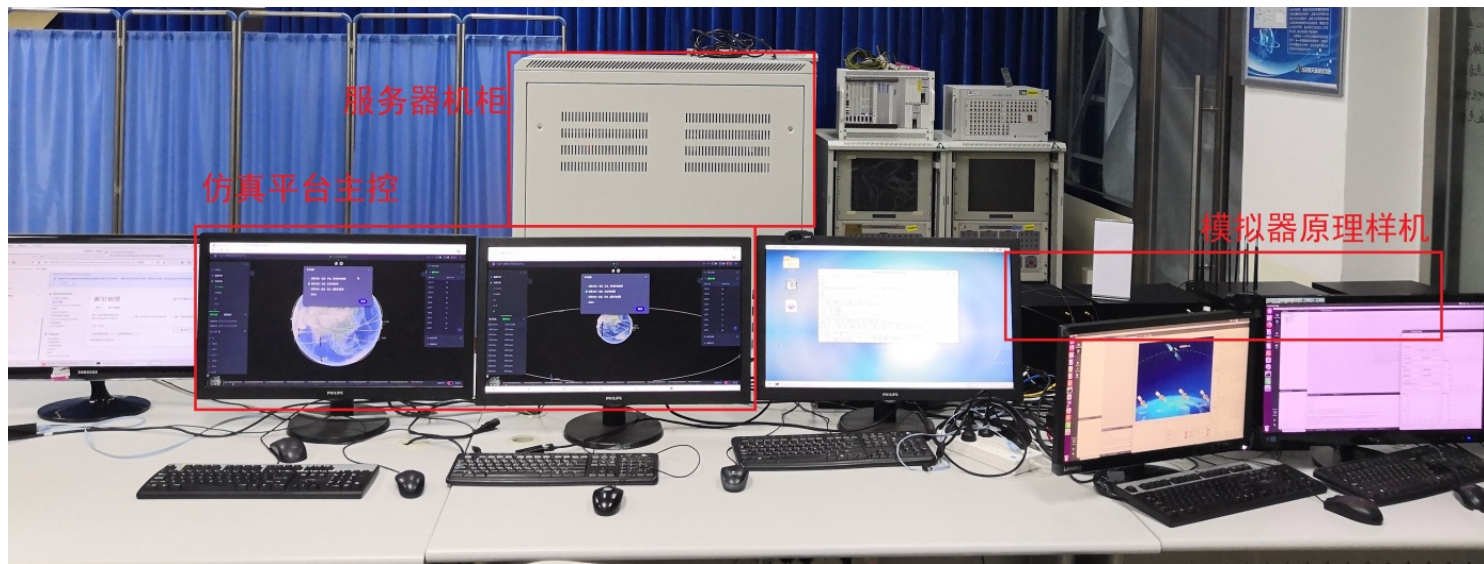

3.2 Network simulation and evaluation system

A model-based information flow design and simulation system has been established, supporting simulations at five levels: network level, node level, device level, module level, and component level.

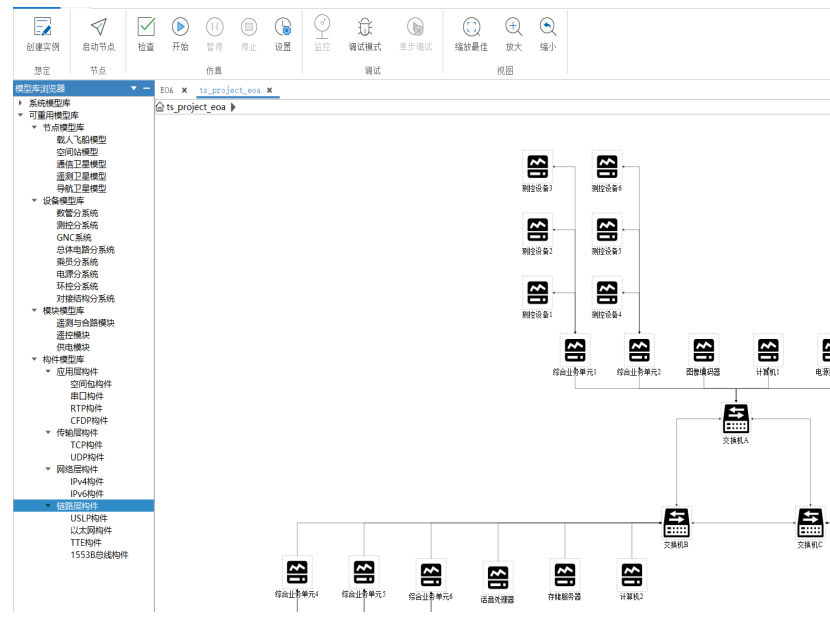
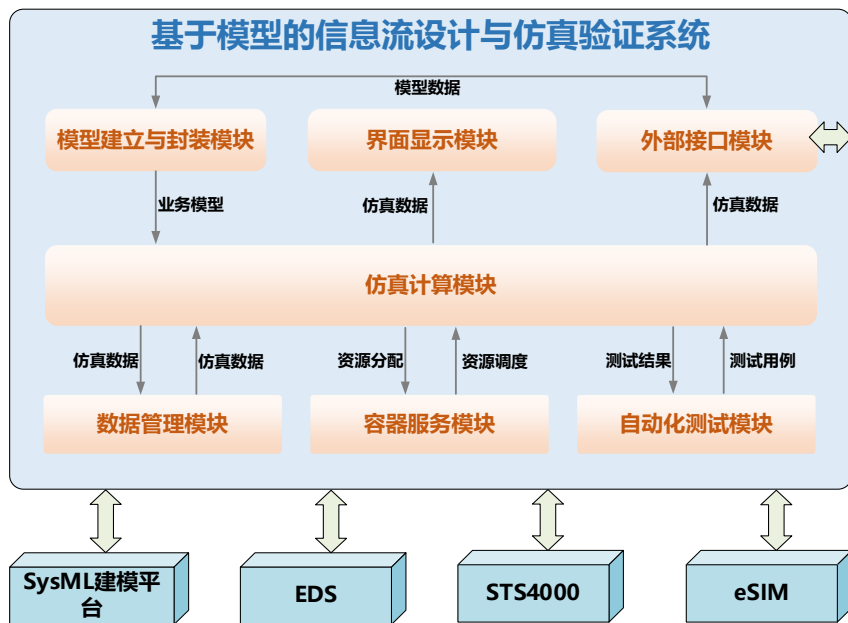

3.3 Hardware Product Design and Implementation

An integrated high-speed routing and reliable switching method has been proposed, and an integrated fusion system has been developed, combining high-speed routers for space networks and intelligent network units for deep space, significantly enhancing the system's communication and networking capabilities.



**high-speed router for
space network I**



**high-speed router for
space network II**

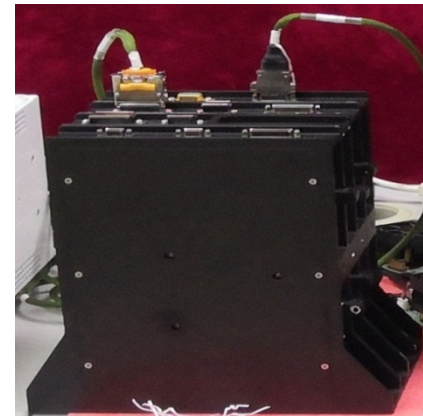

**intelligent network
units for deep space**

3.4 FUHSI Software Architecture and Products

A **F**lexible and **U**nified flig**H**t **S**oftware arch**I**terature (**FUHSI**, 伏羲) and related software components were developed.

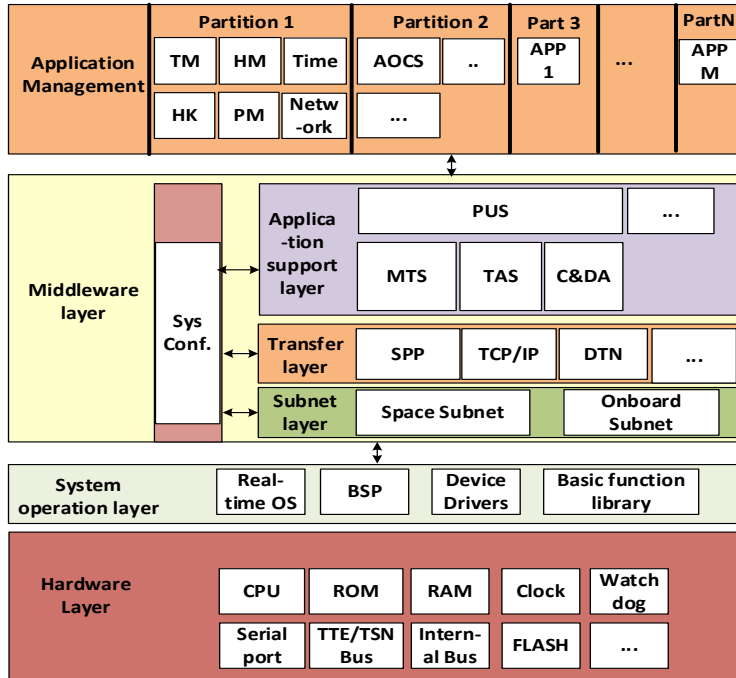

Supported Protocols

- PUS Protocol
- TC Protocol
- AOS Protocol
- USLP Protocol
- COP-1 Protocol
- MTS/AMS Protocol
- CFDP/BP/LTP Protocol
- Device Access Service
- Device Virtualization Service
- Device Data Pooling Service
- Time Access Service
- Space Packet Protocol
- TCP/UDP/IP Protocol
- SN Packet Service
- SN Memory Access Service
- TTE/TSN Protocol
- 1553B/CAN Protocol
- Serial Protocol
- ...

3 Key Achievements

3.4 FUHSI Software Architecture and Products

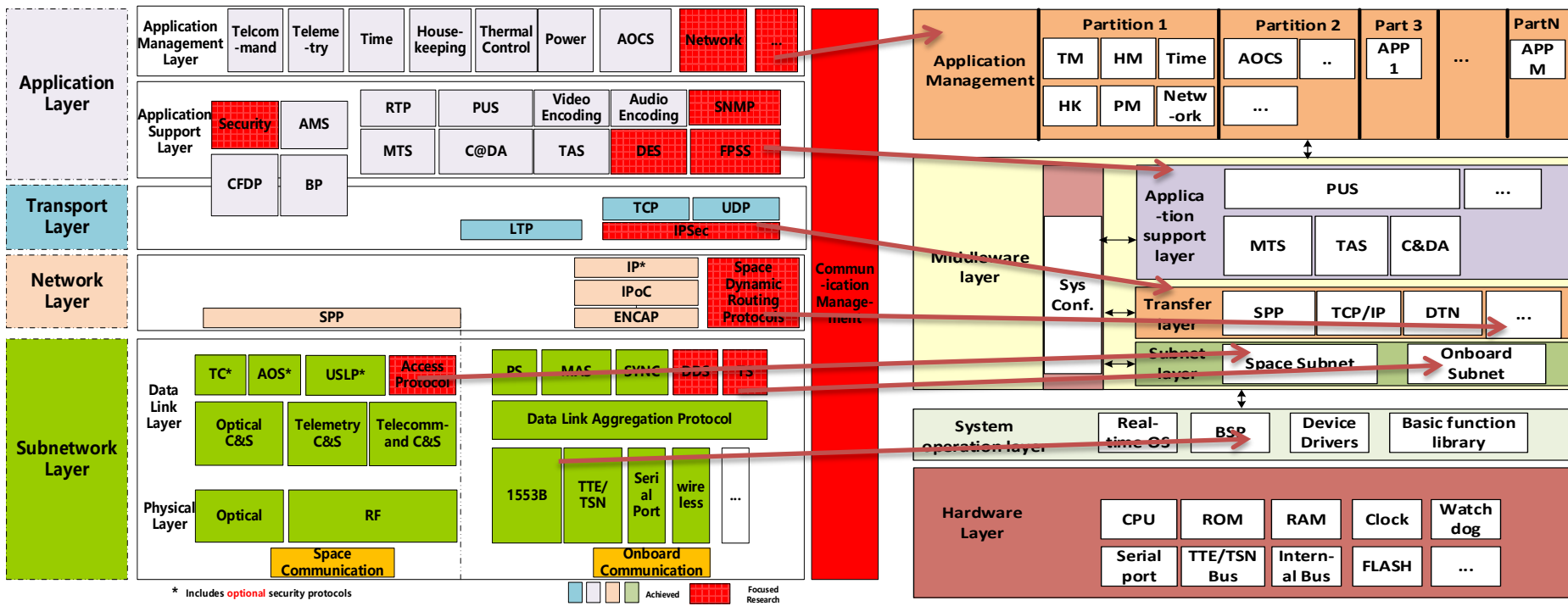

Earth-Moon integrated network protocol architecture

FUHSI software architecture

3.4 FUHSI Software Architecture and Products

Published the CCSDS recommendation “CAST Flight Software as a CCSDS Onboard Reference Architecture”, and two monographs.

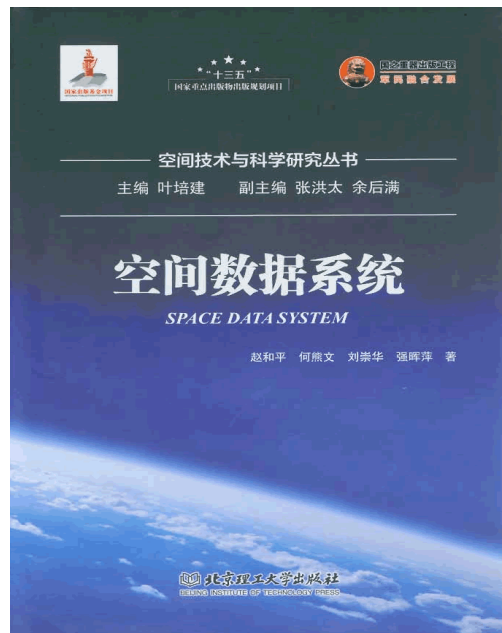
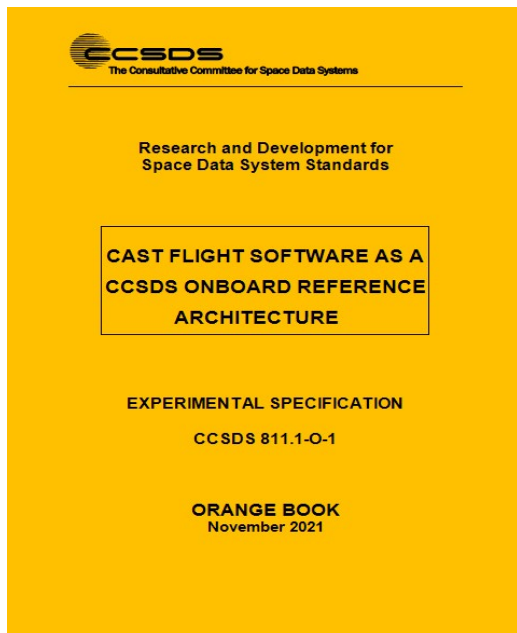

3.5 Ground Verification System

Developed Space Network Router and Onboard TSN Switch, significantly improving the communication networking ability of the system.

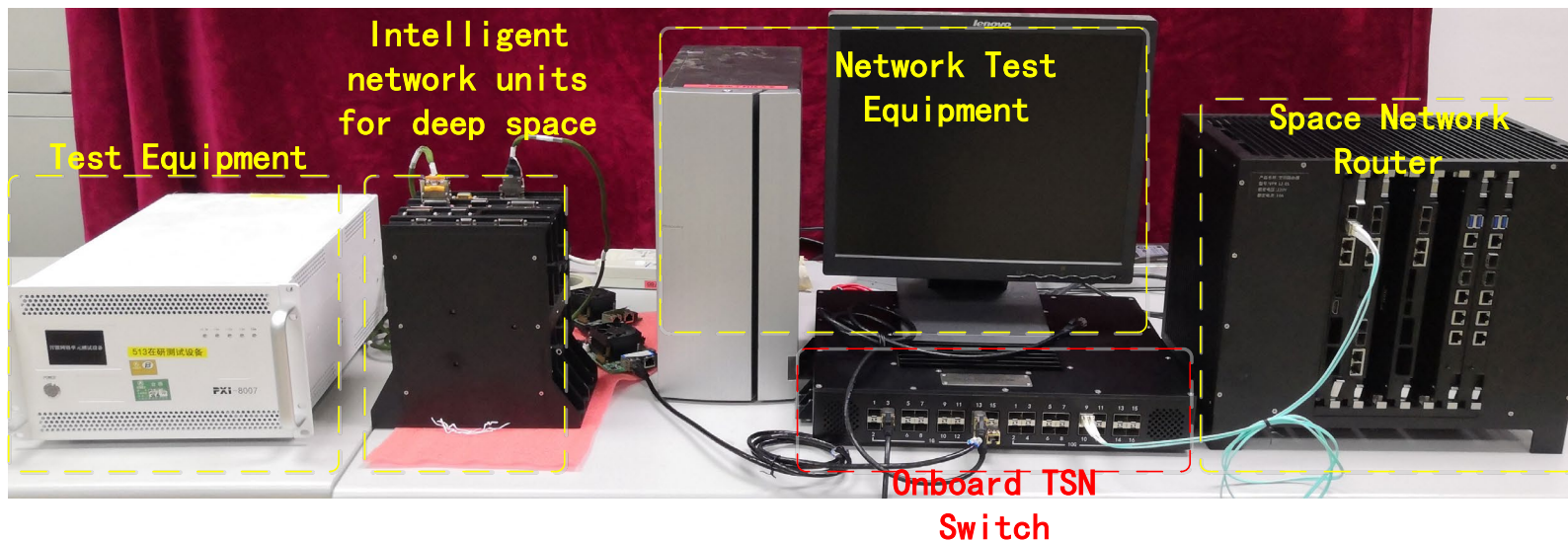

3.6 On-Orbit Validation System

In 2024, in-orbit validation of protocols and software architectures integrating CCSDS SLS/SOIS, PUS, TSN, and others was conducted. Further validation of protocols such as CFDP, BP, LTP, and USLP is planned for the future.

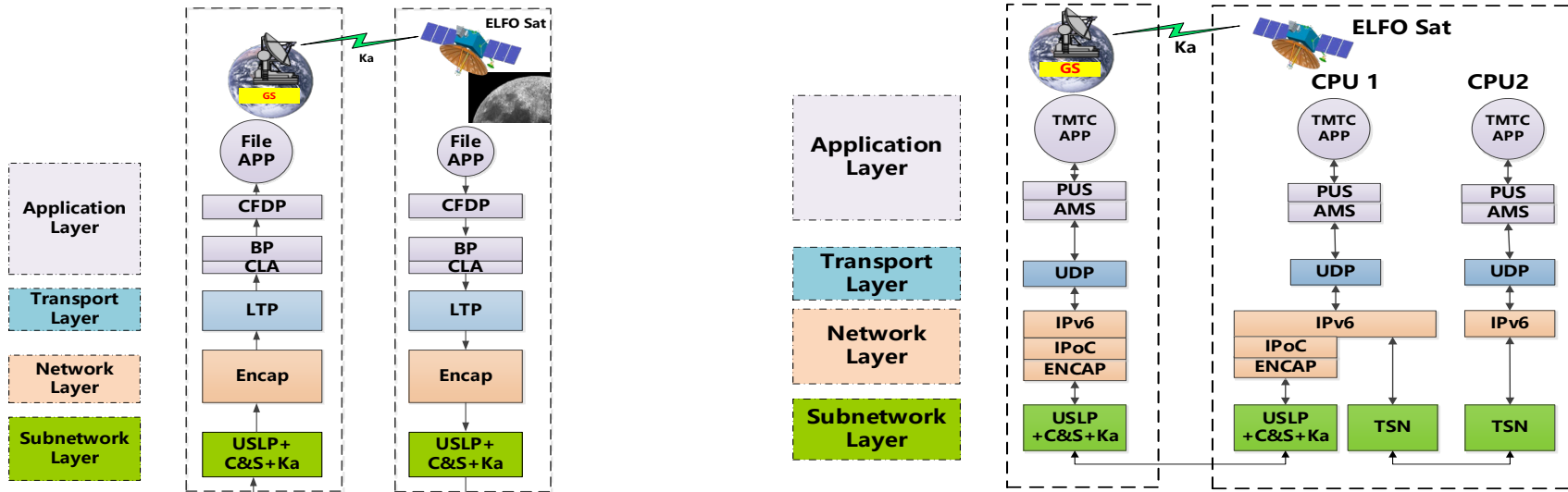

in collaboration with Professor Kanglian Zhao, Professor Zhigang Sun and Professor Tao Li , etc.

An illustration of space exploration. In the upper portion, three satellites are shown in orbit against a blue background with light trails. In the lower portion, a lunar lander and a rover are depicted on the surface of the moon.

Catalogue

1

Background Requirements

2

Current Research Status

3

Key Achievements

4

Expected Effect & Prospect

4.1 Expected Application Effect

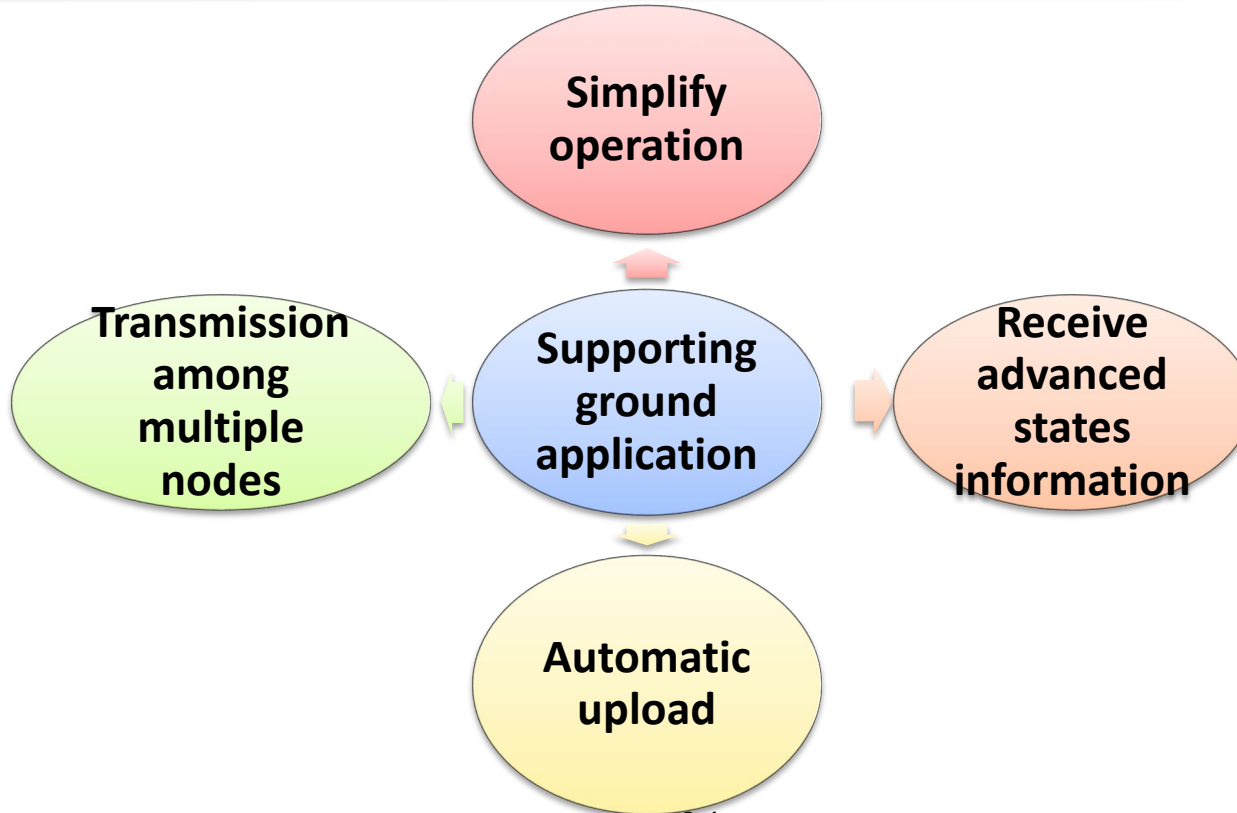

4.1 Expected Application Effect

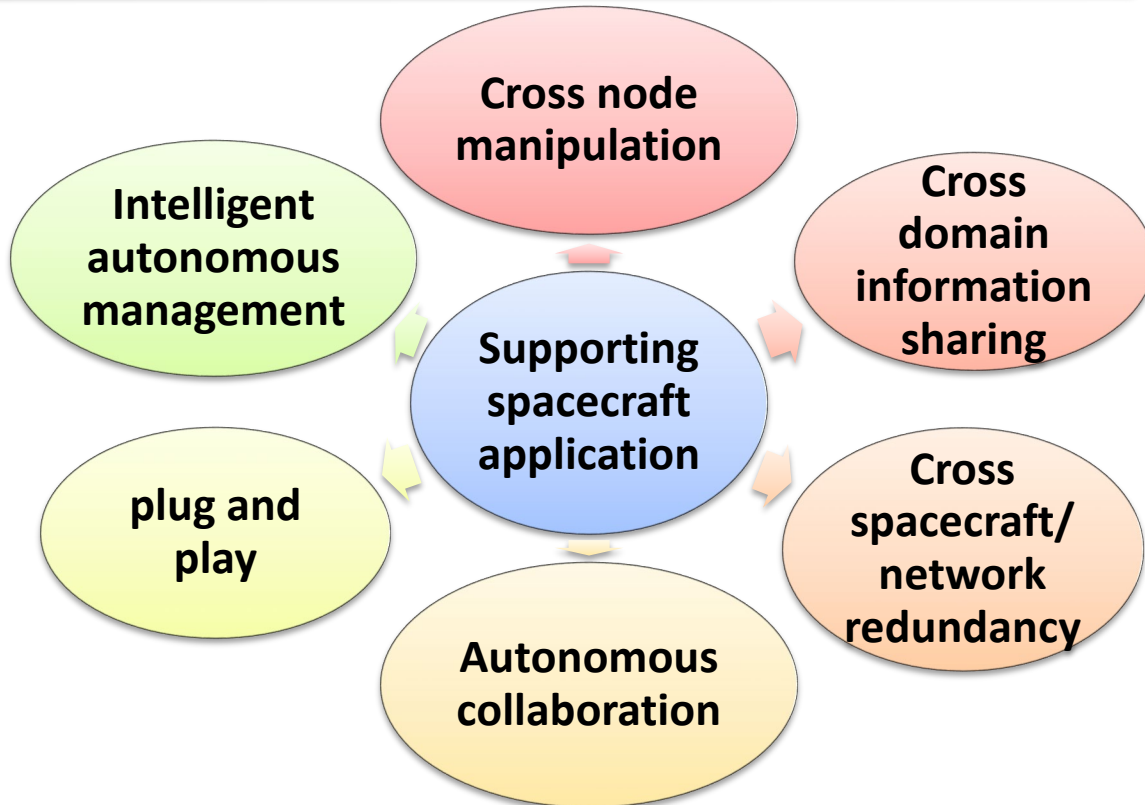

4.2 Prospect

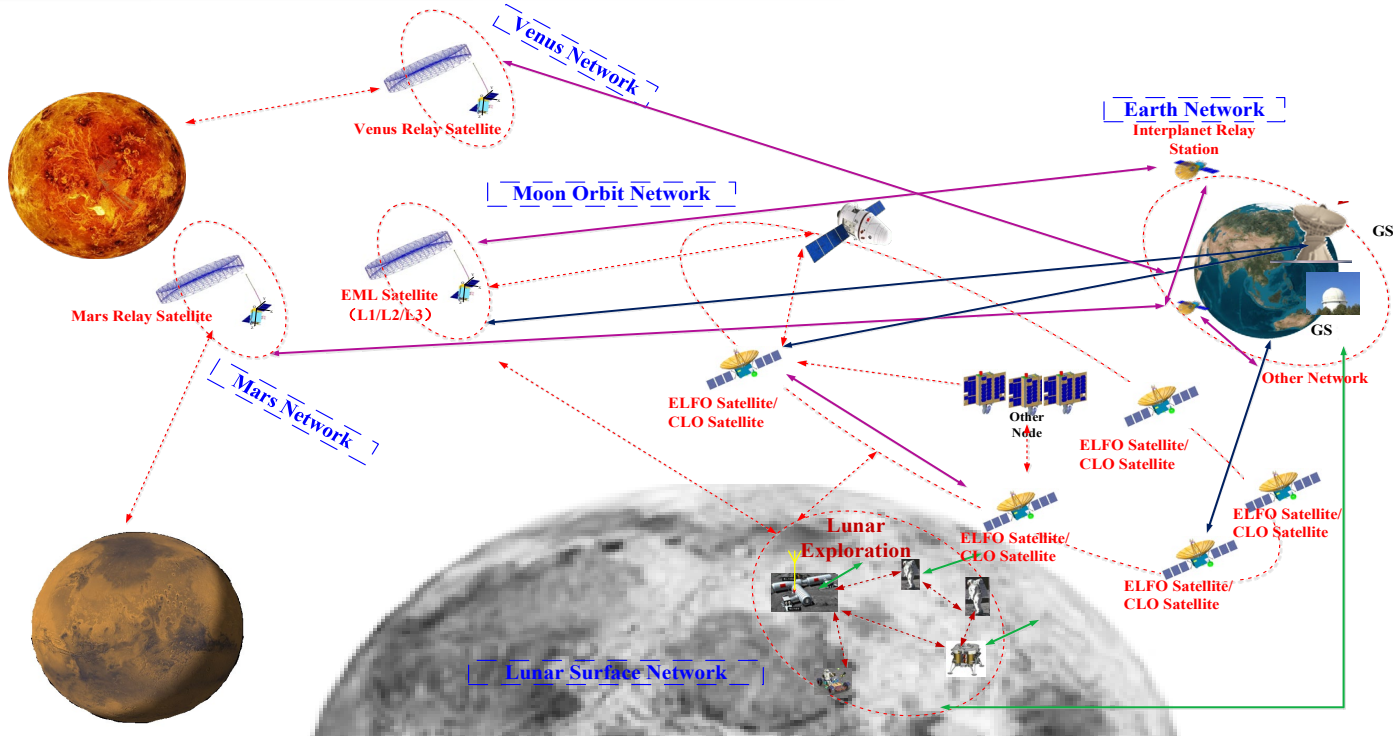

Build a Earth-Moon Integrated Network, and to a Interplanetary Network.



Thanks!

中华人民共和国万岁

世界人民大团结万岁