

IP Routing in the Global Information Grid (GIG)

and similar networks

11 July 2006

Dow Street, OSD NII
dow.street@linquest.com

Discussion Outline ⁽¹⁾

- Background
- GIG Network Description
- Network Mobility
- Routing Commons
- Related Non-GIG Networks
- Summary

Background ⁽¹⁾

- OSD NII and DISA are leading a large-scale system engineering activity to define the overall network architecture for the Global Information Grid (GIG).
- The GIG is likely to push the limits of current approaches and protocols in several areas: routing, QOS, security, etc.
- The GIG Routing Working Group (GRWG) is focused on the IP routing.
- There was some discussion of this routing problem at the IETF-64 GIG BOF.

Background ⁽²⁾

- To be economically viable, the GIG will need to heavily leverage commercial hardware and software.
- However, it will be difficult to meet GIG requirements with the current protocols.
- The current planning goes to 2015+, which gives some time for modifying existing protocols or developing a new routing model.
- There will likely be overlap in the requirements for GIG routing, future Internet routing, and other emerging networks.
- One possibility is that GIG routing and Internet IDR will evolve together to an architecture that meets the requirements of both.
- Purpose of this talk is to update the IETF community on the initial conclusions of the GRWG and continue framing requirements for the next phase of IP routing work.

GIG Network Description ⁽¹⁾

- The GIG will be a large network:
 - working estimate of 10^5 routers, 10^7 hosts within 12 years
 - a few small developments or changes in paradigm could push that to 10^6 routers
- The GIG will include many sub-administrations within a single, overarching technical authority.
- The GIG will have a wide range of node and link types, from carrier class backbone networks to human portable, battery powered devices.
- The GIG will be global in scope.
- The GIG will support critical operations.
- The GIG will (in all likelihood) make use of IPv6 as the packet format and common convergence layer for enabling connectivity.

GIG Network Description ⁽²⁾

Two primary, underlying differences between the Internet and the GIG have been observed that significantly impact the applicability of the the Internet domain model (and BGP):

- *the nature of network mobility*
- *the nature of routing commons*

Network Mobility ⁽¹⁾ - Overview

- Support for network mobility is a *fundamental consideration* in the GIG architecture, not an “add-on” feature.
- The GIG will comprise a large number of globally dispersed, geographically mobile networks.
- Many of these networks will be carried on vehicles.
- Vehicle based networks will make up large sections of the *network infrastructure* as well as connecting to the edge.
- A vehicle will often carry multiple network components that are “wired” together, and connect to other vehicles over a variety of wireless RF links.

Network Mobility ⁽²⁾ - Overview

- There will be an indirect relationship between geographic mobility and network topology change due to the significant heterogeneity of RF link types.
- Network construction will often occur as an ancillary effect of vehicle movement in support of some other objective.
- One could argue that developing the GIG routing system is more like “growing a MANET into an inter-domain routing system” than “adding mobility to the Internet routing model”.
- When viewed in the context of existing protocols, the GIG is probably somewhere between these two paradigms. This talk focuses on the problem as approached from the IDR/BGP side.

Network Mobility ⁽³⁾ - Internet Model vs GIG

Internet model: assumes that the network topology is relatively stable and that peering occurs in a *deliberate* manner, particularly between entities of different technical administrations. Most links are wired, and topology construction is a “man-in-the-loop” event.

- relatively stable topology
- deliberate peering and wired links
- topology construction and routing configuration with a man-in-the-loop

Network Mobility ⁽⁴⁾ - Internet Model vs GIG

GIG: must support pervasive node and network mobility for infrastructure nodes as well as edge networks. In many cases, the network topology of the GIG will result from operational factors that are unrelated to routing, requiring the routing system to adapt to ongoing changes. Many links are wireless, and topology construction cannot require a “man-in-the-loop”.

- dynamic topology
- ad-hoc peering and wireless links
- network topology as a side-effect of other factors
- topology construction and routing configuration without a man-in-the-loop

Network Mobility ⁽⁵⁾ - Impact of Dynamic Topology

Dynamic topology due to node mobility affects BGP at two levels:

Router Level Graph:

Changes to the router level topology can impact *AS composition*, causing a number of potential problems for standard BGP operation. These result primarily from the “loose” administrative coupling between inter and intra-domain protocols and the router level topology.

AS Level Graph:

Changes to the AS level topology impact the convergence and stability properties of BGP. In addition, most routing policy in the Internet is related to the AS's location in the larger AS graph, making it difficult to design policies that continue to “make sense” as the AS graph changes.

There is some degree of trade-off between these depending on how the AS boundaries are drawn.

Network Mobility ⁽⁶⁾ - Impact of Dynamic Router Level Graph

In the Internet domain model there is a correlation between:

1. A single technical administration
2. A contiguous piece of the router graph
3. A BGP autonomous system and unique AS number

In addition, 4. routers residing at the topological “border gateway” of the AS sub-graph run BGP.

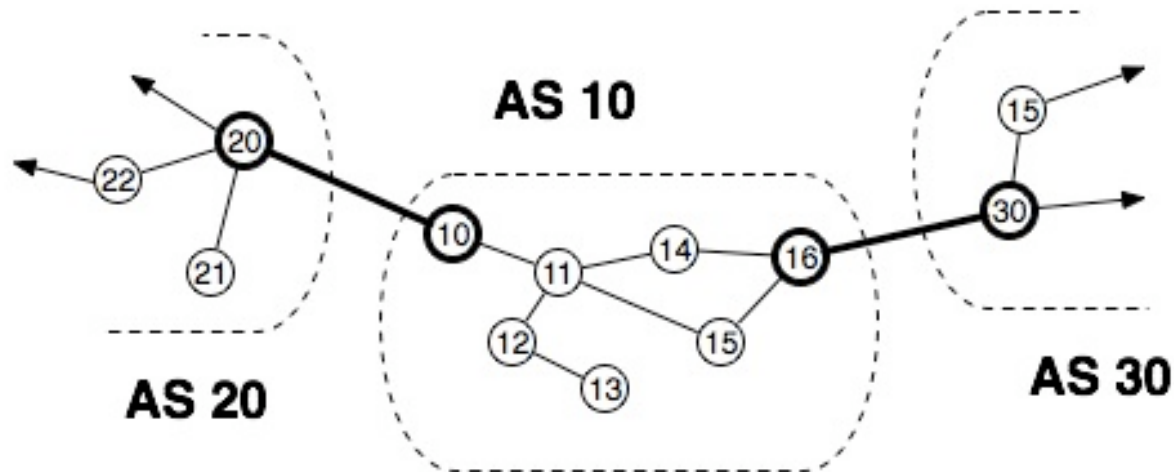

Network Mobility ⁽⁷⁾ - Impact of Dynamic Router Level Graph

When these conditions are met, BGP “makes sense” and operates correctly:

- A. Only a subset of routers in the AS need to run BGP. These BGP speakers, in addition to advertising their own directly connected prefixes to other AS(s), also originate BGP routes for internal routers not running BGP.
- B. Policy implemented at the AS level makes sense because all nodes within the AS are under the same technical administration.
- C. Policy for the AS can be implemented by the BGP speakers residing at border gateways.
- D. BGP loop detection works correctly.

These conditions have traditionally been met through deliberate topology construction and router configuration, and will not “hold naturally” in the face of ongoing changes to the underlying router level graph.

Network Mobility ⁽⁸⁾ - Impact of Dynamic Router Level Graph

Conditions that can result due to mobility or ad-hoc peering at the router level:

- new node/prefix joins the internal topology of the AS
- nodes of mixed admin within a single AS
- internal-to-internal link established
- topology change causes as AS to become disjoint

Network Mobility ⁽⁹⁾ - Dynamic Router Graph / AS Composition

Example 1: New node joins an existing AS.

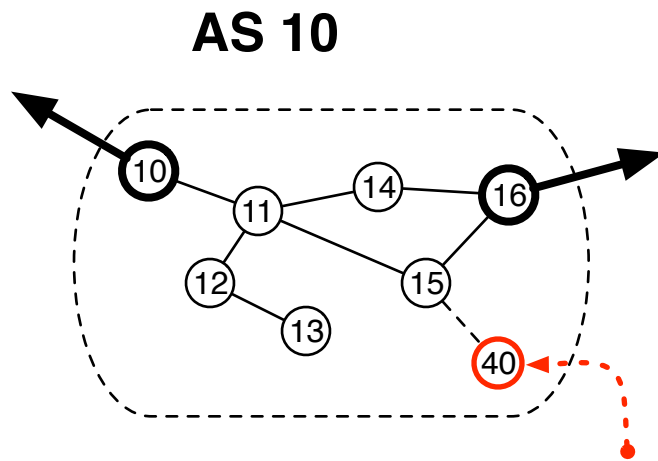

- New prefix is not within original range, but we want it to be reachable outside the AS.
- Which routes to originate (and with what properties?)
- Could have different policy requirements than existing nodes (different admin).

Network Mobility ⁽¹⁰⁾ - Dynamic Router Graph / AS Composition

Example 2: “Internal link” established between existing AS(s)

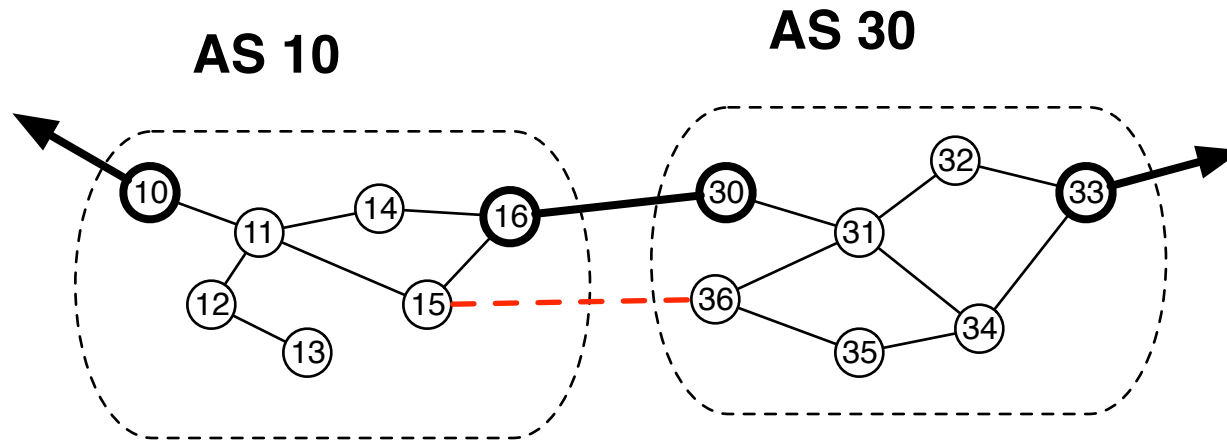

- Ad-hoc link between internal (non-BGP) routers.
- Intended policy at domain boundary is no longer enforced.
- AS sovereignty is violated - may result in merging IGP domains.
- Unpredictable routing behavior results, especially as this condition becomes more prevalent.

Network Mobility ⁽¹¹⁾ - Dynamic Router Graph / AS Composition

Example 3: Topology change causes an existing AS to become disjoint.

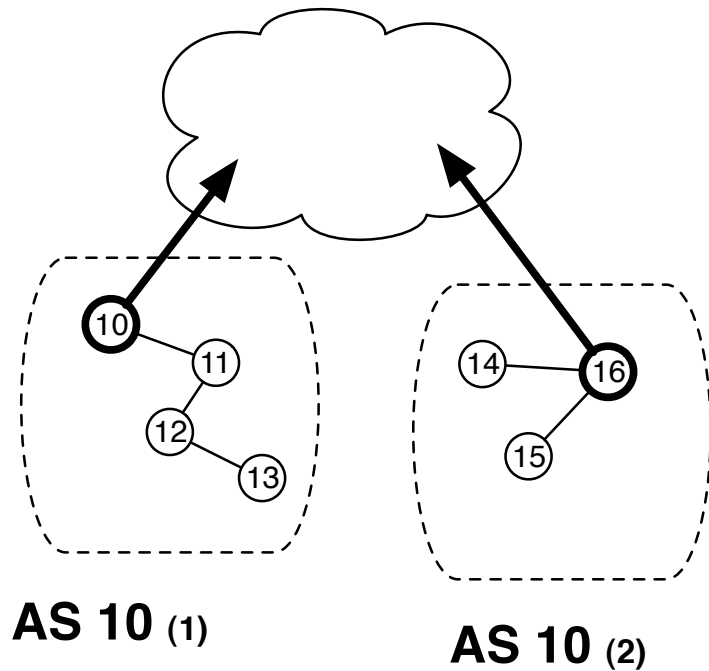

- Loop detection prevents connectivity
- Can easily occur in critical situations

Network Mobility ⁽¹²⁾ - Dynamic Router Graph / AS Composition

Can the AS composition problem be avoided through placement of AS boundaries?

Large AS

- AS is large enough that all topology change occurs fully within a single AS
- i.e. Entire mobile region of the GIG within a single AS
- Benefits: AS cannot be fragmented, no internal-to-internal links, AS membership should be knowable a priori (which routes to originate, but not necessarily what attributes)
- Problem: all scalability and policy requirements are moved into the IGP - haven't really solved anything.

Network Mobility ⁽¹³⁾ - Dynamic Router Graph / AS Composition

Can the AS composition problem be avoided through placement of AS boundaries?

Small AS

- AS is small enough that all topology change only occurs at AS boundaries
- i.e. Separate, unique AS for each independently mobile entity (vehicle)
- Benefits: AS cannot be fragmented, no internal-to-internal links, AS membership is fixed and known, fine grained policy
- Problem: BGP would need to be changed to support dynamic peering
- Problem: Significantly more dynamic AS level graph than in the Internet
- Problem: Potential complexity and convergence problems due to large number of AS(s) and wide AS level graph (10's of AS hops)

Network Mobility ⁽¹⁴⁾ - Dynamic Router Graph / AS Composition

- The bottom line is that an “administratively configured” linking between router topology, IGP (internal routing), and EGP will not work in a dynamic topology where mobility and/or topology change spans multiple AS(s). This is not really news...
- This problem is referred to (in this talk) as the AS composition problem.
- BGP AS is used to accomplish multiple goals (scalability, stability, policy)
- There has been some work in the dynamic introduction or construction of topology abstractions (e.g. clustering) for reachability, scalability, stability, etc
- There has been somewhat less work in this area as related to routing policy.

Network Mobility ⁽¹⁵⁾ - Dynamic Router Graph / AS Composition

- In a dynamic topology, we probably need an abstraction that adapts to changes without a human in the loop.
- However, the form and/or scope of the abstraction may well differ for scalability, policy, and other goals.
- e.g. Per-vehicle policy would be great if it didn't bring along with it per-vehicle convergence.
- Assume we solve the AS composition problem (small AS, extend BGP, etc). To be useful, the AS would still probably need to be of "medium" size, leading to a fairly dynamic AS level graph.

Network Mobility ⁽¹⁶⁾ - Impact of Dynamic AS Level Graph

Consider changes to the AS level graph due to AS mobility:

In constructing BGP policy, an AS administrator will often take into account:

- A. The neighbor AS(s) with which the AS is peering
- B. The nature of connectivity to these neighbors (num. of links, capacity, etc)
- C. Location within the larger AS topology
- D. Any underlying economic goals

The usefulness of BGP policy may well be related to how well the policy can be tuned to reflect these factors. In a dynamic AS level graph, factors A-C are subject to change (D is considered later in routing commons discussion).

Difficult to develop policies that will continue to work well after topology change unless the policy is quite general.

Network Mobility ⁽¹⁷⁾ - Impact of Dynamic AS Level Graph

Consider changes to the AS level graph due to intermittent inter-AS links.

- Some neighboring AS(s) will peer over just one link
- This link may well be a wireless RF link
- Vehicle mobility can in turn cause a flap in the connectivity of the AS graph
- In some cases, this link could be within the interior of a “meshy” topology.
- Some work for all BGP routers with routes that traverse this link.
- More work for shortest path routes that traverse this link.

Additional analysis is required here to better understand the impact. The problem may be even worse than initially expected due to high connectivity requirements (see any-to-any).

Network Mobility ⁽¹⁸⁾ - Impact of Mobility on Routing Security

Consider implications of mobility on security models that “check against a known good.”

- Some of the initial work in securing IDR is based on prior knowledge about which prefixes should be where.
- Ex. fixed mapping often assumed between a prefix and an originating AS.
- When the AS level graph and AS composition are changing, it is difficult to apply a model that checks against a known good.
- Furthermore, subgraphs will often need to operate without connectivity back to a central authority (for keys, etc).
- Probably need a model of dynamically constructed trust (another simple problem).

Network Mobility ⁽¹⁹⁾

Can we change the problem to “single hop” mobility?

- Geographic mobility leads to the use of wireless RF links
- Capabilities of an RF system are limited by physical properties (size, weight, power, range, capacity,etc)
- For many vehicles, the scope of geographic mobility will exceed the scope/ range of their organic RF systems
- Wide coverage systems (SATCOM) are limited in capacity, number of supported units, or the type of terminal equipment required for high BW links (vehicle SWAP).
- Even if a GIG-wide, single hop mobility system could be designed, a multiple-link, meshed topology is desirable for increased robustness and survivability.
- Local, multi-hop LOS connectivity reduces the load on limited SATCOM assets and can provide lower latency

Network Mobility (20)

Can we solve the problem “outside of routing” (e.g. MIP)?

- A principle goal of the GIG is to enable communication between any pair of connected users, even when the network is fragmented into disconnected sub-graphs.
- There will invariably be critical situations when IP connectivity exists between endpoints, but the intermediate node (i.e. home agent) is unreachable.
- Even when full connectivity exists, the scarcity of RF capacity drives toward direct path routing whenever possible.
- This is not to say that mobility approaches based on intermediate nodes are irrelevant in the GIG design, only that they cannot provide a complete solution.

Network Mobility (21)

- It is difficult to untangle the impact of mobility from the discussion of applying the Internet model/BGP to the GIG.
- However, assume we solve the problems related to AS composition and a relatively dynamic AS level graph. Can BGP then meet the requirements of GIG routing?
- Next consideration is the nature of the network commons...

Routing Commons ⁽¹⁾

What is a routing commons?

- Routing is a distributed, *inherently cooperative* activity with some set of global goals that most or all of the component nodes/networks are trying to achieve.
- Individual nodes or network entities may also have local goals that are independent of the global goals. Individual nodes may need to balance achieving local goals vs. contributing to the global goals of the larger system.
- A *routing commons* is defined as the model by which individual nodes or entities cooperate and compete in contributing resources to the larger routing activity (achieving global goals).

Disclaimer: we're still early on in characterizing this problem - there may be existing work that can be applied.

Routing Commons ⁽²⁾ - Routing Commons in the Internet

Two general forms of routing commons are currently seen in the Internet:

IGP (altruistic)

- Traditional IGP routing has been “fully cooperative” in that all nodes fully contribute resources to achieving the goals of the domain.
- The single domain authority can dictatorially modify resource use for any component nodes (adjust routing metrics).

BGP (economic)

- Current inter-domain routing balances cooperation and competition through the use of BGP policy and topology control via peering agreements.
- This process is heavily influenced by the economic interests of the participating parties and an interest in full Internet connectivity.
- There is no overarching authority that dictates routing policy (other than the out-of-band market forces.)

Routing Commons ⁽³⁾ - Routing Commons in the GIG

The GIG routing commons can be described as *mission-oriented*, and does not map well to either the altruistic or economic commons of Internet.

GIG (mission-oriented)

- Single overarching authority for all GIG assets with (in theory) dictatorial control over sub-administrations, but limited ability to enforce rules.
- Users cooperate to complete mission goals, but compete for resources that improve quality of life. Also, some mission goals of local scope.
- No underlying economic market - may be more difficult to quantify a successful or optimal balance between local and global goals.
- Requirement for rapid resource re-allocation according to changing mission and topology.
- (Perhaps) more complex, indirect relationship between achieving mission goals and allocating network resources. (i.e. missions involve a large, dynamic set of participants)

Routing Commons ⁽⁴⁾ - GIG Common Resource Scarcity

- There will be certain limited resources in the GIG which must be applied toward meeting mission objectives in a manner that spans the interests of sub-administrations.
- An important example is RF capacity - RF spectrum is a scarce and valuable resource and efficient use of this resource is an important global goal.
- Often the path cost will be dominated by a single RF link, either in terms of capacity or latency. Yet, this single link cost can easily be lost in the AS abstraction.
- In a similar manner, it is important not to introduce unneeded RF hops. This can be an inadvertent result of introducing BGP AS boundaries for other reasons. (i.e. the shortest AS path is not the path with the fewest RF hops.)
- Efficient use of RF may also lead toward shortest path routing, requiring a much higher number of AS(s) peering as “siblings.” This will impact the characteristics of the BGP graph.

Routing Commons ⁽⁵⁾ - GIG Any-to-Any Connectivity

- An important goal of the GIG routing system is to provide connectivity between any two endpoints for which there is an IP path.
- Essentially, the routing system, or the distribution of topology information, should not be the limiting factor in enabling connectivity.
- For example, if the GIG used BGP then every AS would need *to be able to* act as a transit network for every source / destination pair.
- This is a substantial difference between the GIG and Internet IDR.
- It is currently unclear whether this is technically feasible goal, or whether BGP is well suited for this type of connectivity.

Routing Commons ⁽⁶⁾ - Nature of the GIG AS Graph

AS level topology:

- Depending on how AS boundaries are drawn, it is quite likely that the GIG AS graph would differ from the Internet AS graph in key characteristics.
- If per-vehicle policy were required, the GIG could be many AS hops wide.
- GIG networks would have neither the opportunity at the physical layer nor the economic motivation to peer in a manner similar to the Internet. This may yield a very different topology. (not power law degree distribution)

BGP policy graph:

- A much larger number of “sibling” peering relationships could be expected so as to more closely approach “shortest path”.
- Nodes may not be able to afford the latency or cost in long-haul RF resources to route through the “core”.
- Additionally, connectivity must be maintained during “core” failure events if an alternate IP path remains.

Routing Commons ⁽⁷⁾ - GIG Destination Based Policy

- BGP policy is oriented toward destination address.
- In the Internet, there is a fairly strong correlation between a specific customer and their identifying address block. This allows ISPs to implement policies for customers by implementing policies for destination prefixes.
- Per customer policy is sufficient given the opportunity to over-provision and the physical characteristics of the network infrastructure.
- In the GIG it is likely that multiple, simultaneous paths between a source destination pair will need to be supported since an all-purpose path is not able to be provisioned.
- Ex. Two traffic flows with the same destination address may have different quality of protection requirements, leading to routes which transit a different set of AS(s).
- Ex. The same source / destination pair may require simultaneous low latency and high capacity routes for different traffic types.

Routing Commons ⁽⁸⁾ - Vector Nature of BGP / Policy Hiding / Security

- The vector nature of BGP hides (or obscures) some information about network topology and currently configured policy.
- This *may* be useful to ISPs because it allows certain aspects of their business model to also remain obscured.
- However, there are well known limitations of vector routing due to these topology hiding properties.
- The GIG does not have the same business interests in hiding topology information, and could leverage greater topology transparency to simplify management, add functionality for anomaly detection, etc.

Routing Commons ⁽⁹⁾ - GIG Routing Stability vs. Response

- In applying resources to meet mission objectives, it is likely that users or networks within the GIG will vary in the criticality of their connectivity.
- For low priority users / networks, the routing system could be tuned to favor overall GIG stability over responsiveness to network changes (in order to maximize connectivity).
- For high priority users / networks, the routing system must be able to permit increased control plane overhead in order to maximize responsiveness.
- This is an especially important consideration given the high number of intermittent RF links.
- The single, overarching authority and global goals again play a role - methods used for balancing stability vs. response are unlikely to be effective unless the mechanisms are distributed.
- Ex. Coordinated, multi-AS route damping or min route / LSA origination timers based on a function (not fixed).

Routing Commons ⁽¹⁰⁾ - **GIG Multi-homed Bottleneck Links**

- Vehicles will often have capacity requirements which exceed the capacity available over a single RF link.
- In these cases, the routing system will need to support efficient, simultaneous use of multiple, “local bottleneck links”.
- A similar problem can be observed in the Internet, where a customer AS connects to multiple upstream providers.
- The GIG case may be different in that it may not be technically feasible to increase the capacity of a single link.
- An addition, the changing network topology will make load distribution more difficult.

Routing Commons ⁽¹¹⁾ - Operating Environment

- Many of the routers in the GIG will be physically located in geographically remote areas.
- While some remote management will be possible, there will always be times (often the most critical) when sections of the network must operate independently of the network core.
- Most day-to-day operators of the network will have only minimal expertise in network routing, requiring the routing system to be largely self-configuring and optimizing.
- The routing system must support an abstraction that enables translating user intent (with respect to resource allocation) into protocol / configuration.

Related Non-GIG Networks ⁽¹⁾

- There are probably a few emerging networks that are reasonably GIG similar:
 - Other government / military networks
 - Emergency / disaster response networks
- Some of these problems are also on the horizon for Internet IDR (or here today but are currently unresolved).
- Perhaps the greatest overlap is with ad-hoc, configuration-free networks.
 - Wireless routers are cheap and are being deployed everywhere
 - Convenience of RF puts pressure on this common resource (new community commons)
 - Soon to be 4-byte AS numbers (how will this impact ASN allocation and AS topology of the Internet?)
- Solving these problems should enable widespread vehicle-based networks (where vehicles could be people, etc).

Summary ⁽¹⁾

- The GIG requirements for routing are still being worked and should make it into an Internet Draft in the coming months.
- These requirements describe the target or goal, with the realization that it may take a long time to get there.
- We can probably get some of the way by extending BGP / evolving IDR.
- A full solution may well require a new routing paradigm (possibly built on existing MANET work).
- The GRWG will coordinate with IETF / IRTF / research community in parallel.
- Fairly long term effort - need to find the overlap with other work.

- Many of these problems have been around for a while...
- The GIG is probably going to be built regardless of how well they are solved in the coming years, and will end up making use of whatever routing technology is available and implemented in commercial gear.