

Off-the-shelf MPTCP proxy

Jordan Melzer

jordan.melzer@telus.com

IETF 91

MPTCP Use Case: Bonding over WiFi

- Multipath access over home and neighbour DSL
 - 2+ paths give higher reliability and speeds
- MPTCP proxies at home gateway and ISP router
- Prototyped on Linux at Algonquin College

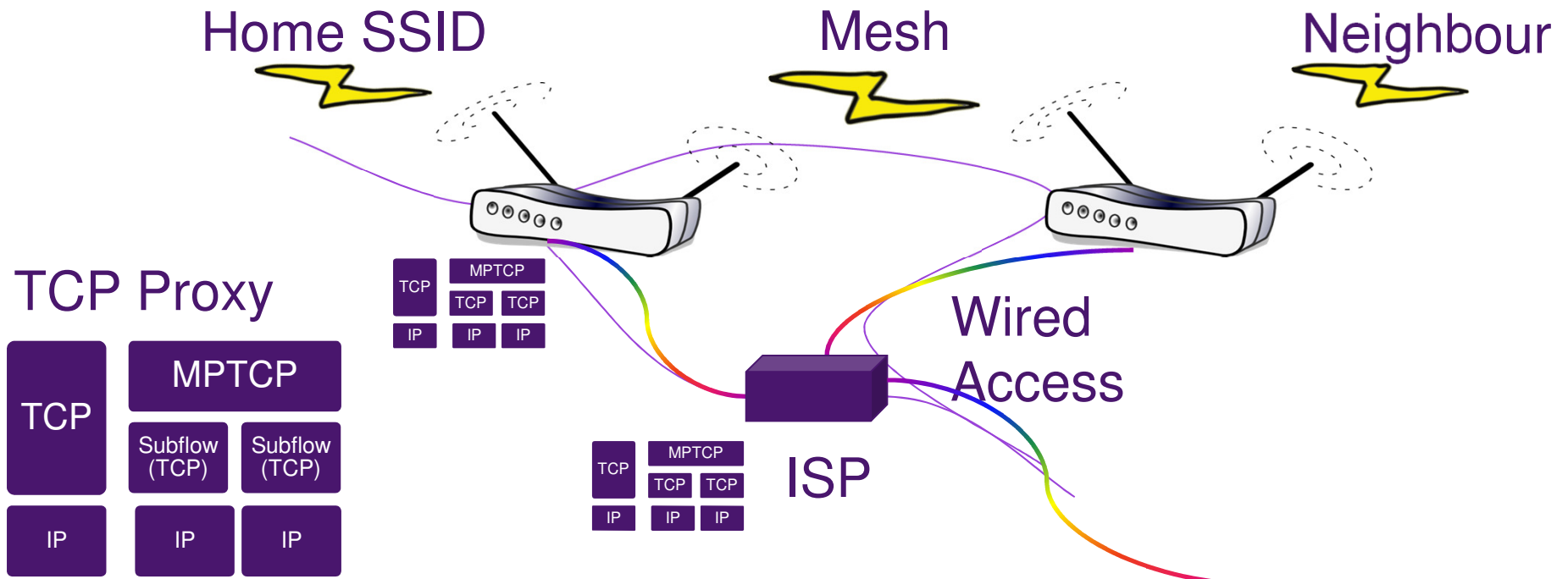

Proxy Design

- UCL MPTCP kernel + TCP interception proxy
- Standard TCP interception proxy – Mallory
 - Terminates both TCP and MPTCP sessions, copies data between them
 - Plugin architecture allows data & socket manipulation
 - Kernel converts TCP to MPTCP automatically
- Works when one or neither side is MPTCP enabled
- If both sides are MPTCP enabled
 - Proxy works when all flows are on-path
 - If first flow is on-path, off-path flows won't be recognized by server
 - If first flow is off-path, on-path flows won't be recognized by server
- Possible to allow mix of on / off-path through plug-in?

Resources

- Mallory:

- <https://intrepidusgroup.com/insight/mallory/>

- UCL MPTCP Linux kernel implementation:

- www.multipath-tcp.org