

SFC Header Mapping for Legacy SF

draft-song-sfc-legacy-sf-mapping-03

Haibin Song (haibin.song@huawei.com)
Jianjie You (youjianjie@huawei.com)
Lucy Yong (lucy.yong@huawei.com)
Yuanlong Jiang (jiangyuanlong@huawei.com)
Linda Dunbar (ldunbar@huawei.com)
Nicolas Bouthors (nicolas.bouthors@qosmos.com)

Motivation

- Existing SFs may not be able to support SFC solution developed here
- SFC Proxy is used b/w SFF and SFC-unaware SFs

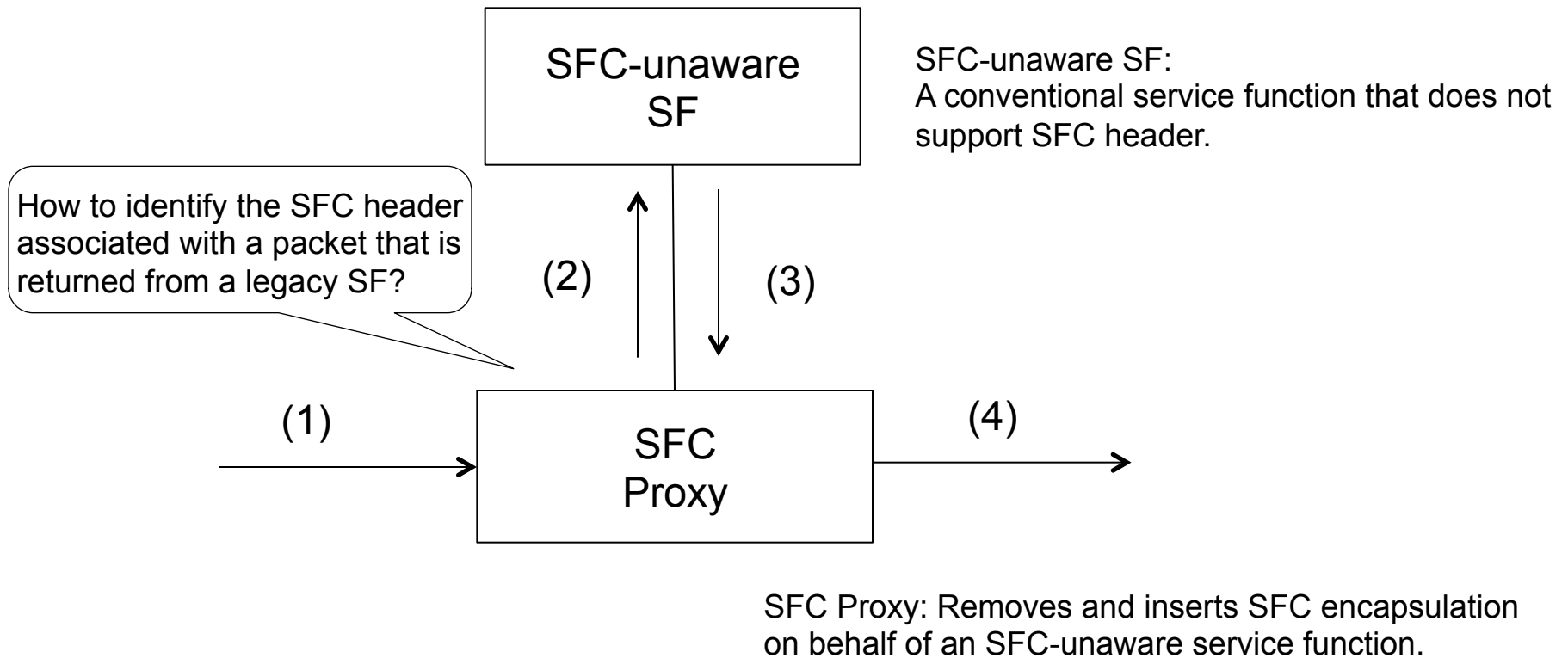

For Transparent SF

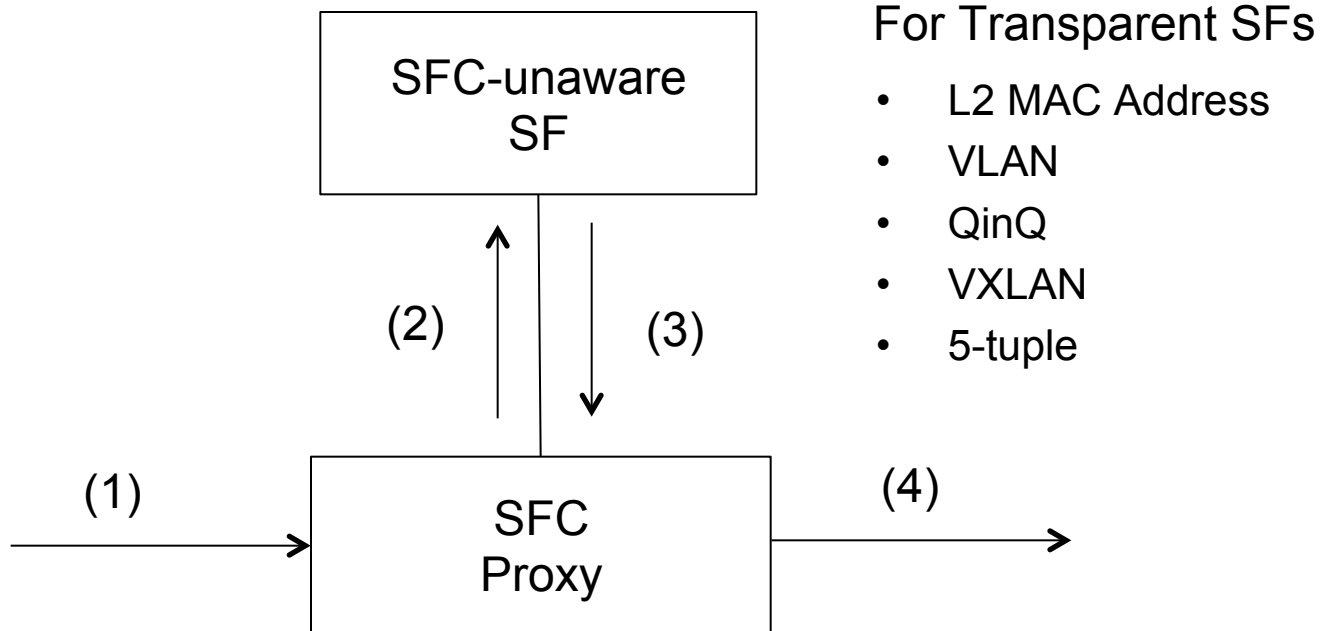

Transparent SF: A service function that does not change any bit of the original service packet header (Layer 2, layer 3, and layer 4) sent to it, but it may drop packets.

For Non-Transparent SF

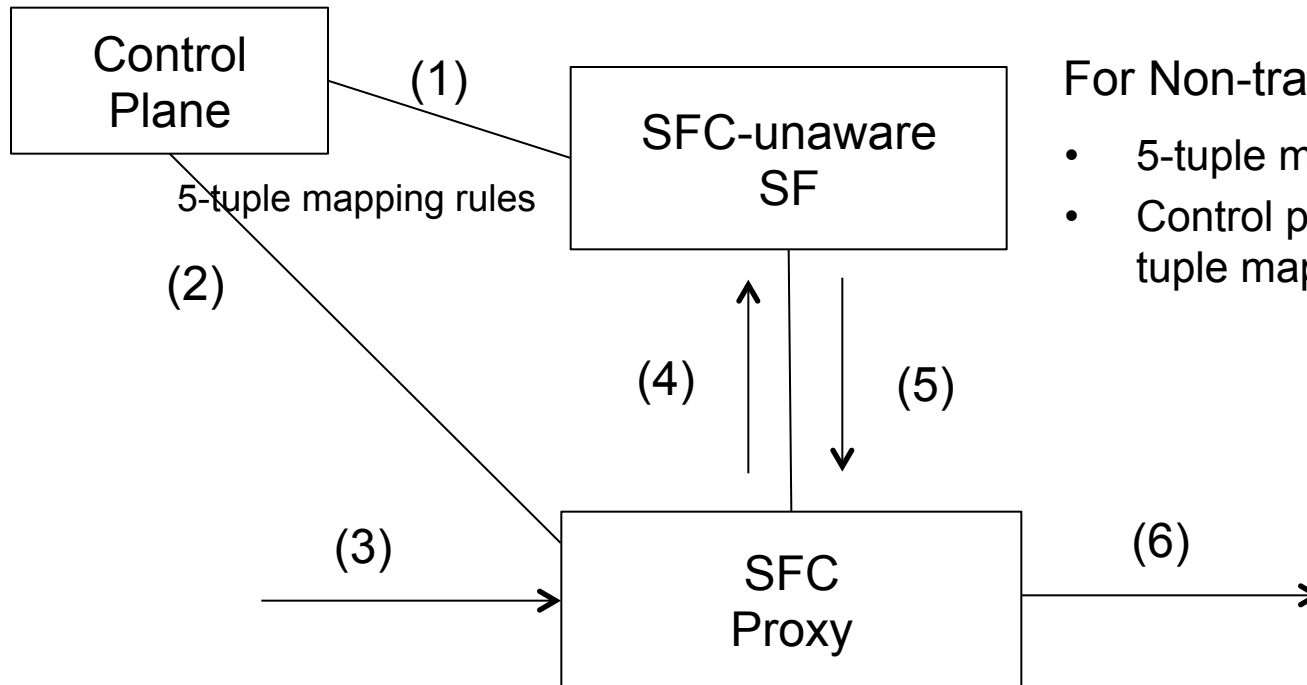

For Non-transparent SFs

- 5-tuple mapping
- Control plane provides 5-tuple mapping rules.

Non-transparent SF: A service function that changes some part of the original service packet header sent to it.

Operation Considerations

	Methods	Stored Key-Value	Application Scenario
For Trans-parent SF	MAC Address	(Source MAC Address, SFC header) e.g. assign a source MAC address per path ID	L2 header won't be modified by the SF.
	VLAN	(VLAN ID, SFC header) e.g. assign a VLAN ID per path ID	L2 header won't be modified by the SF.
	QinQ	(Outer VLAN ID, SFC header) e.g. assign an outer VLAN ID per path ID	The SF is required to support QinQ. L2 header won't be modified by the SF.
	VXLAN	(VNI, SFC header) e.g. assign a VNI per path ID	The SF is required to support VXLAN.
	5-tuple	(5-tuple, SFC header) The SFC proxy maintains the mapping table for 5-tuple and the SFC header.	5-tuple is not modified by the SF.
For Non-trans-parent SF	TBD	Mapping rules: e.g. 5-tuple -> 5-tuple' SFC Proxy: 5-tuple -> 5-tuple' 5-tuple'-> SFC header	The SFC proxy is configured or is able to obtain the mapping rules of the SF. The SF modifies the 5-tuple based on the mapping rules.

Next Steps

- Solicit comments from the WG
- Request WG adoption