

IETF

Interim 2024 ANIMA 01

20 Feb 2025

Sheng Jiang
Toerless Eckert
Michael Richardson

This session is being recorded

Note Well

This is a reminder of IETF policies in effect on various topics such as patents or code of conduct. It is only meant to point you in the right direction. Exceptions may apply. The IETF's patent policy and the definition of an IETF "contribution" and "participation" are set forth in BCP 79; please read it carefully.

As a reminder:

- By participating in the IETF, you agree to follow IETF processes and policies.
- If you are aware that any IETF contribution is covered by patents or patent applications that are owned or controlled by you or your sponsor, you must disclose that fact, or not participate in the discussion.
- As a participant in or attendee to any IETF activity you acknowledge that written, audio, video, and photographic records of meetings may be made public.
- Personal information that you provide to IETF will be handled in accordance with the IETF Privacy Statement.
- As a participant or attendee, you agree to work respectfully with other participants; please contact the ombudsteam (<https://www.ietf.org/contact/ombudsteam/>) if you have questions or concerns about this.

Definitive information is in the documents listed below and other IETF BCPS. For advice, please talk to WG chairs or ADs:

- [BCP 9](#) (Internet Standards Process)
- [BCP 25](#) (Working Group processes)
- [BCP 25](#) (Anti-Harassment Procedures)
- [BCP 54](#) (Code of Conduct)
- [BCP 78](#) (Copyright)
- [BCP 79](#) (Patents, Participation)
- <https://www.ietf.org/privacy-policy/>(Privacy Policy)



Relating proposed new work to ANIMA charter

- **ANIMA is an OPS WG to standardize / experiment with in-network automation.**
- **This side meeting is targeted to introduce a range of proposed future work items to the ANIMA community**

Agenda

1. Chair slides
2. Autonomic Distributed troubleshooting, *Bing Leo, Huawei*
3. Knowledge Modeling Method for IP Network Fault Management, *Hanting Dang, Chinese Telecom*
4. Application responsive network, *Yangfeng, China Mobile*
5. Automatic Network Congestion Relief, *Qin Zhao, China Unicom*
6. Autonomic Mobility Capability Negotiation Mechanisms, *Zhiwei Yan, CNNIC*
7. Bootstrap of campus network and Service VLAN Auto-Deployment, *Bing Leo, Huawei*
8. Scenarios of broadband installation and maintenance that only require manual assistance, *Hanting Duan, Chinese Telecom*
9. Distributed Operations in NASR (Network Attestation for Secure Routing), *Peter Liu, Huawei*

Each topic ≤ 10 min slides, ≤ 5 minute discussion



OVERVIEW OF ANIMA FRAMEWORK (ANI, BRSKI/GRASP/ACP)

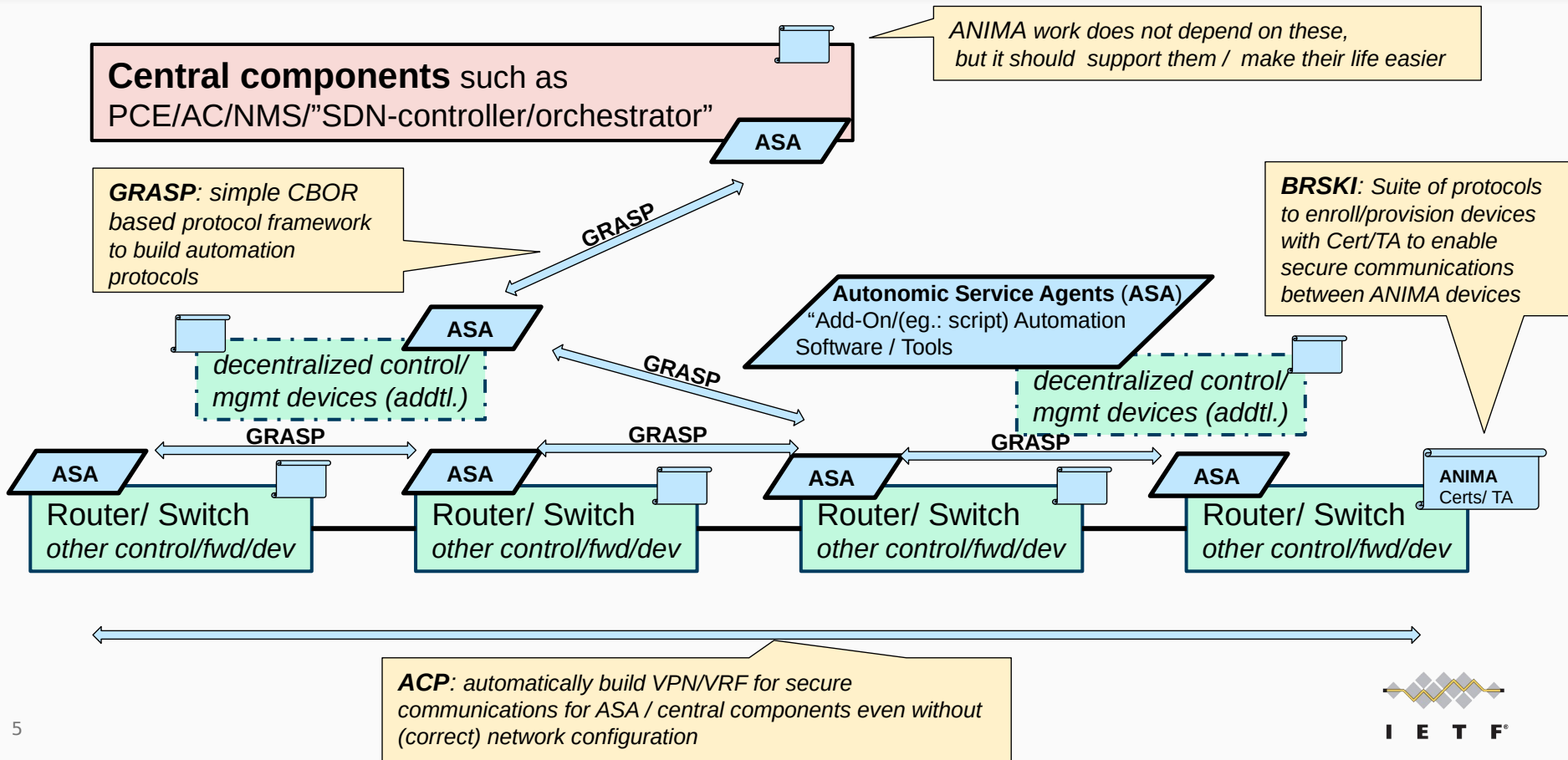

Relating proposed new work to ANIMA charter

Decentralized software agents (ASA): add automation intelligence into the network without requiring central components

- They can run on every or only on some network devices. Or on additional devices, e.g.: “POP-PC used also for other management tools”.
- They can communicate (“southbound”) with the existing control/management software on those devices via existing API: CLI, Netconf/YANG, SNMP, ...
- ASA can provide (“northbound”) API to look like extensions of network device control/management software (preferably Netconf/YANG ?!).
- They can communicate amongst each other with any fitting protocol. If you need to design a new protocol - ANIMA suggests to make it use GRASP
- If needed (likely!) These agents can securely communicate amongst each other and with existing network and central device software due to ANIMA Certs/CA (provisioned by BRSKI - other other mechanisms)
- These agents can discover each other across L2 via (DULL) GRASP
- If needed: These agents can discover each other across L3 via ACP/GRaSP
- If needed: These agents can communicate across L3 even without

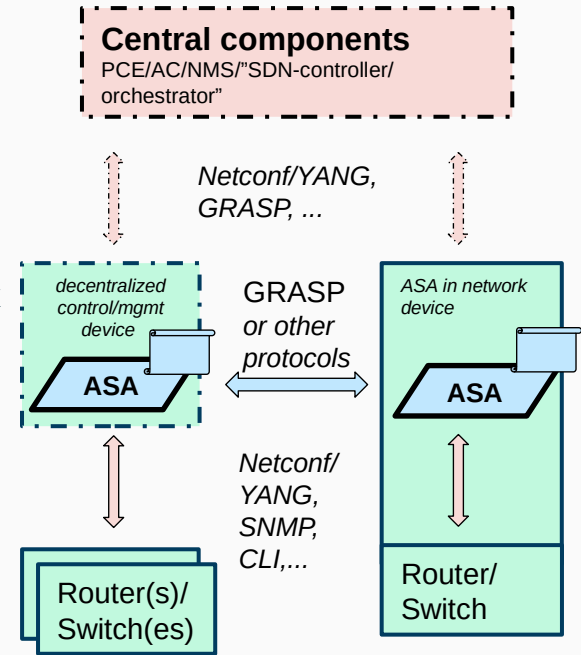

Relating proposed new work to ANIMA charter

- Explain how proposed new work can fit the charter:
 - Extensions/modification to existing ANIMA components CERTS/TA, BRSKI, GRASP, ACP
 - How will new work interwork / integrate with existing solutions/deployments
 - ASA
 - ASA do not need to use any of those pre-existing ANIMA components
 - But only re-invent any existing wheel with good cause (IETF OPS mantra).
- MUST specify enough for a useful minimum “Proof of Concept” deployment example
 - Enough specificity so that independently developed, interoperable implementations can be built from the specifications.
 - Ideally provide PoC source or binary code yourself before WG adoption or during WG work
 - Up to WG to decide when its feasible
 - Sometimes it is easier to first code and then write spec.
 - It is a lot easier to forget a lot of required spec when you do not code.

Summary

- The ANIMA framework allows to define in-network automation through communicating ASA that perform some novel form of Automation Function (AF) and leverage existing / new south, east/west and optionally northbound protocols / data-models