

# Framework for Energy Efficiency Management

draft-belmq-green-framework-  
03

GREEN WG Interim Meeting  
June 16 2025

[Benoit Claise \(Huawei\)](#), Luis Contreras (Telefonica), Jan Lindblad (For.Eco),  
Marisol Palmero (Cisco), Emile Stephan (Orange), Qin Wu (Huawei)

# GREEN Reference Model

From the previous interim

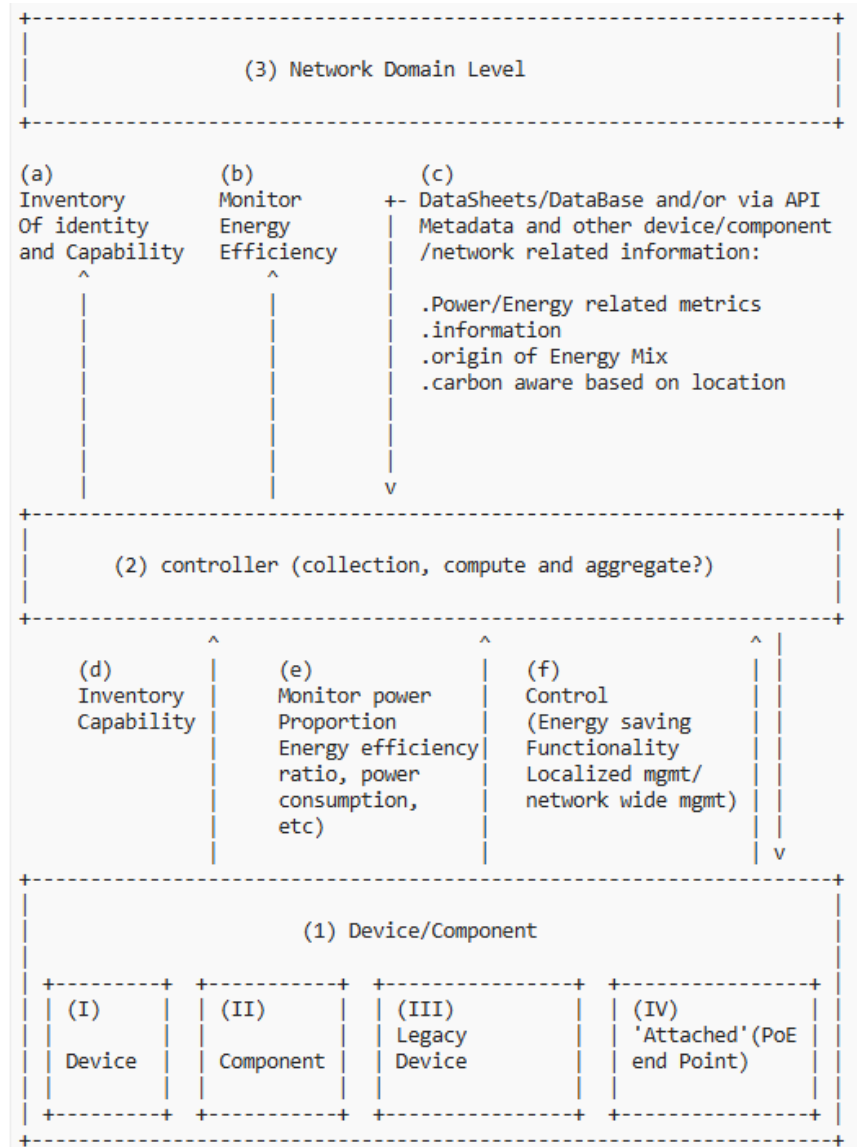

# Example: Physical Meter with Legacy Device

From the previous interim

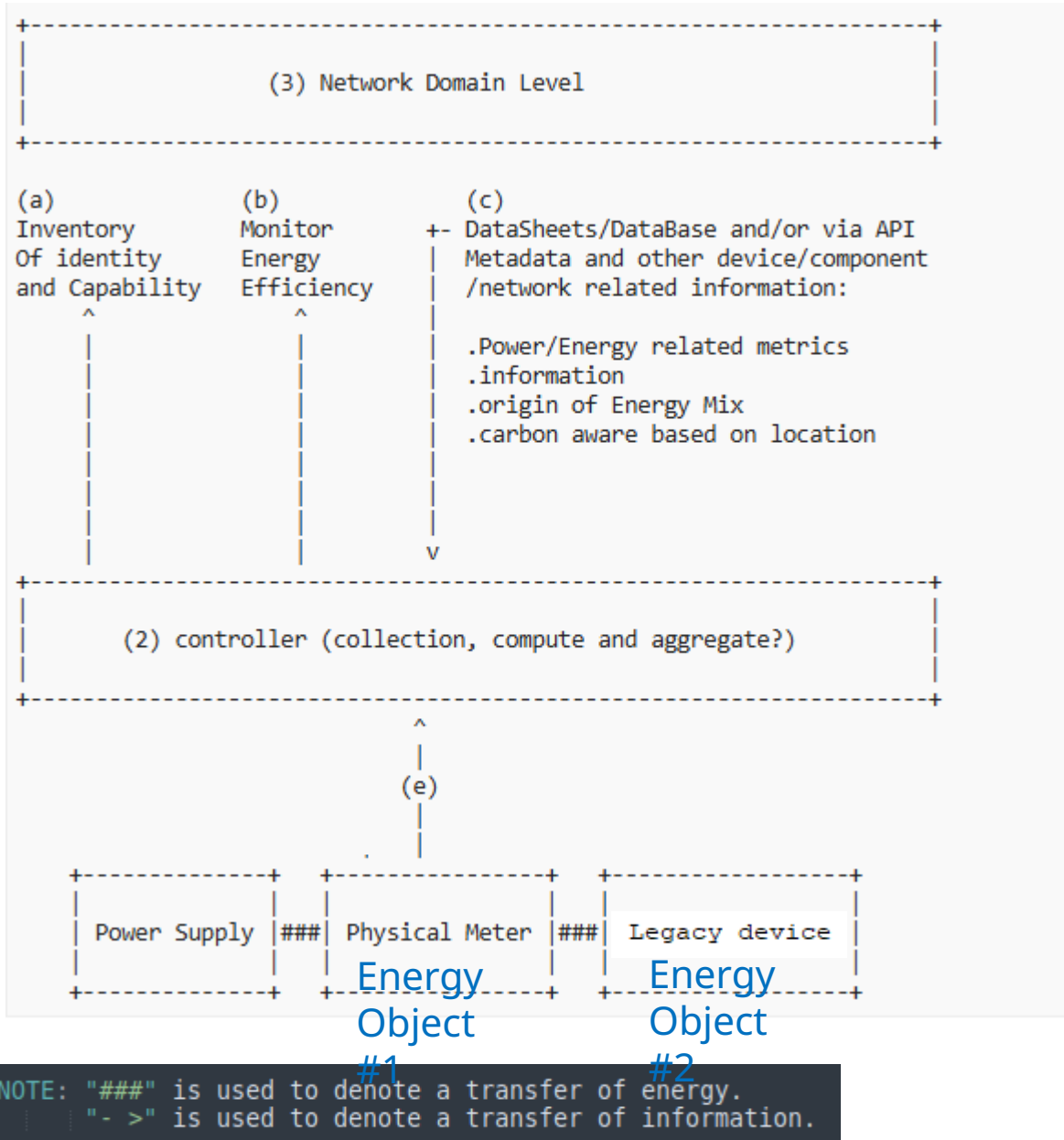

- With legacy devices, the controller (or Network Domain Level) must know & report that the physical meter measures on the behalf of this legacy device.
- In other words, it must know & report that the **Energy Object 1** reports on behalf of **Energy Object 2**
- Conclusion: « Controller must know which for which Energy Object(s) it measures power or energy. This is the **Metering Relationship**”
- No LLDP over energy distribution => so a manual process

NOTE: "###" is used to denote a transfer of energy.  
 "- >" is used to denote a transfer of information.

# Example: Physical Meter with Newer Device

From the previous interim

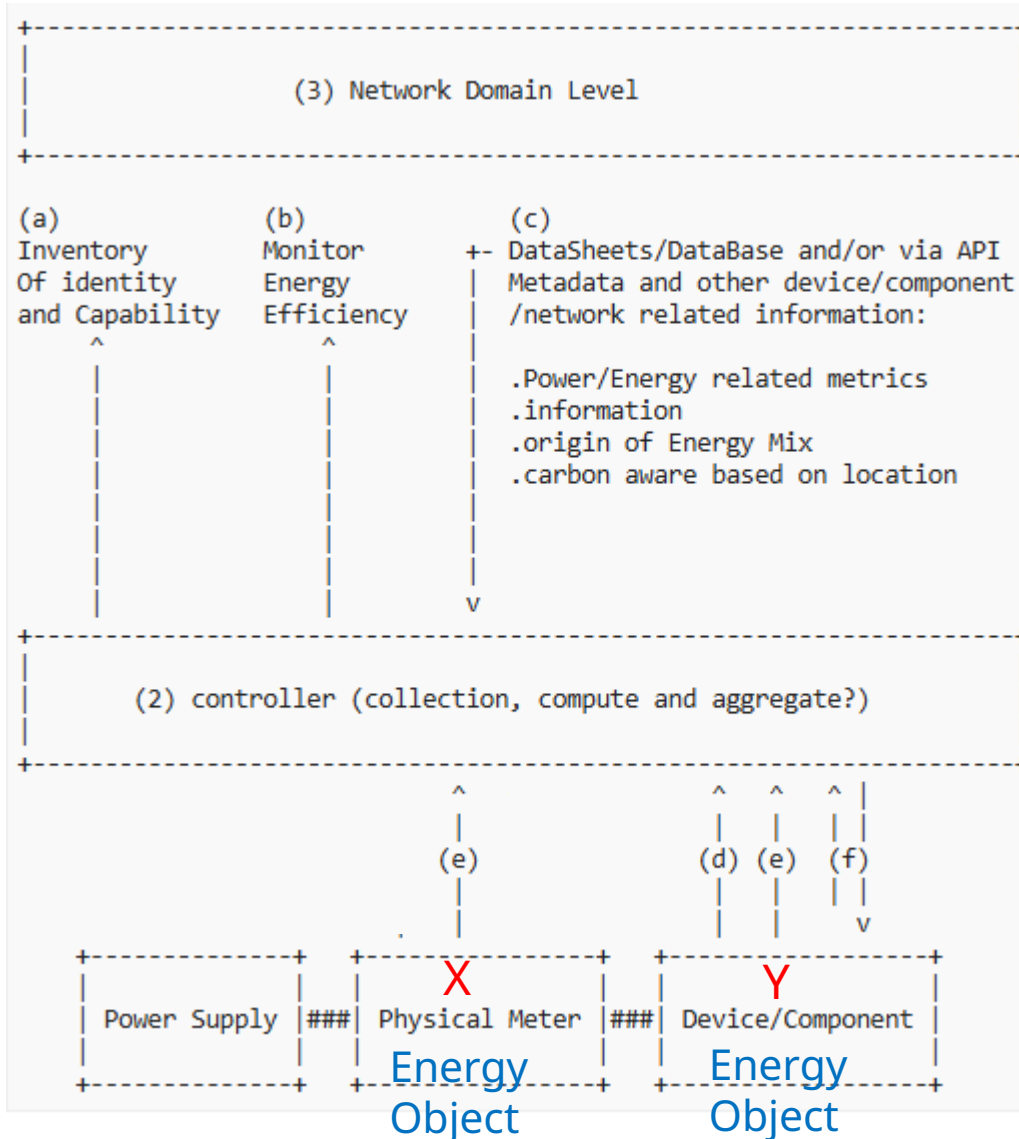

ISSUE: double counting!

- Where to measure?
  - X or Y
  - The physical meter Energy Object or the device/component Energy Object?
- What if the controller can query both? => double-counting issue?
- The controller MUST NOT calculate the sum of all Power Interfaces
- The controller (or Network Domain Level) must know & report that the physical meter measures on the behalf of the device/component, based on (a)
- Conclusion: « Controller must know which for which Energy Object(s) it measures power or energy. This is the Metering

NOTE: "###" is used to denote a transfer of energy.  
"- >" is used to denote a transfer of information.

# Example: Power over Ethernet

From the previous interim

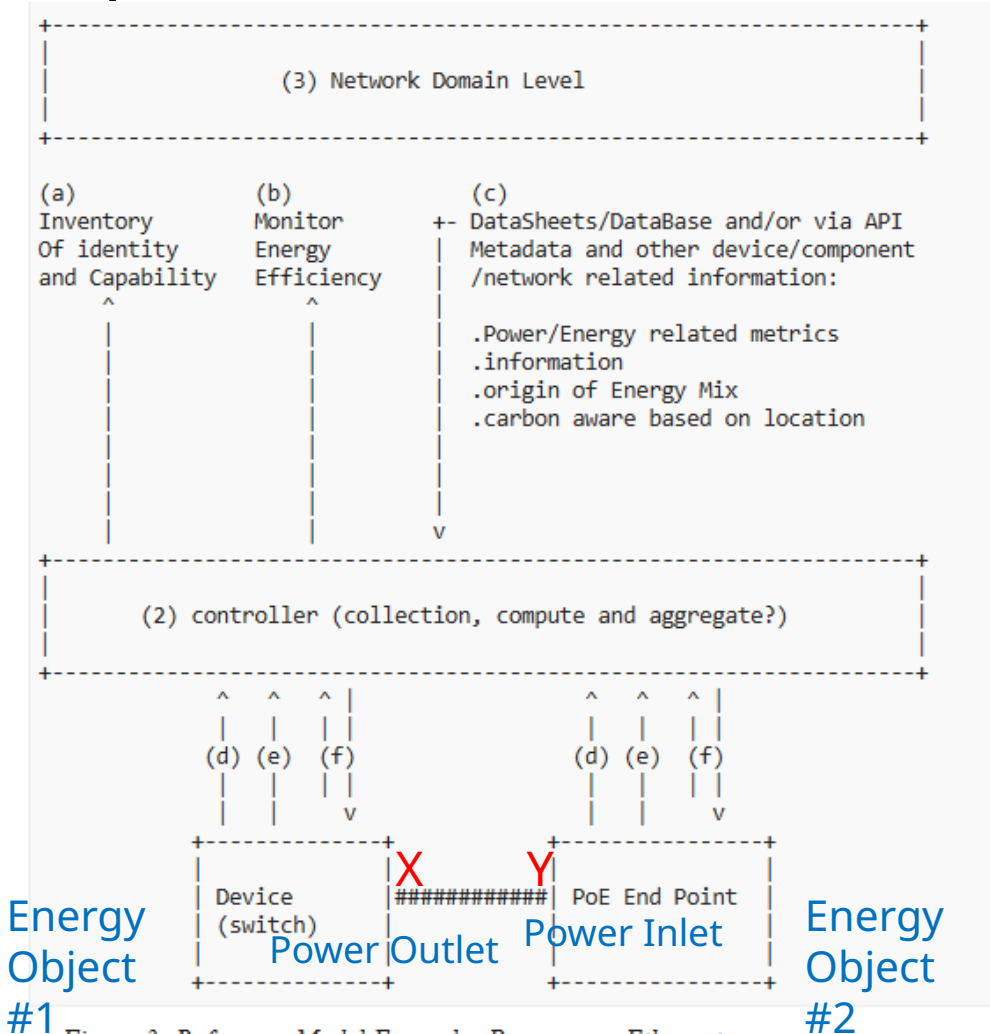

Figure 3: Reference Model Example: Power over Ethernet

ISSUE: controller double counting?

- Same issue as before
- Power Outlet vs Power Inlet

ISSUE #2: who controls what?

- In this case, the PoE port on the switch controls the PoE End Point
- We might have two ways to control the PoE End Point:
  - Power on switch port
  - Power State on the PoE End Point (ex: low energy mode)
- To control the PoE End Point, the controller must know the Power Source Relationship between the two Energy Objects.

NOTE: "###" is used to denote a transfer of energy.  
 "- >" is used to denote a transfer of information.

These are key differences with typical networking frameworks

# Example: Smart PDU

From the previous interim

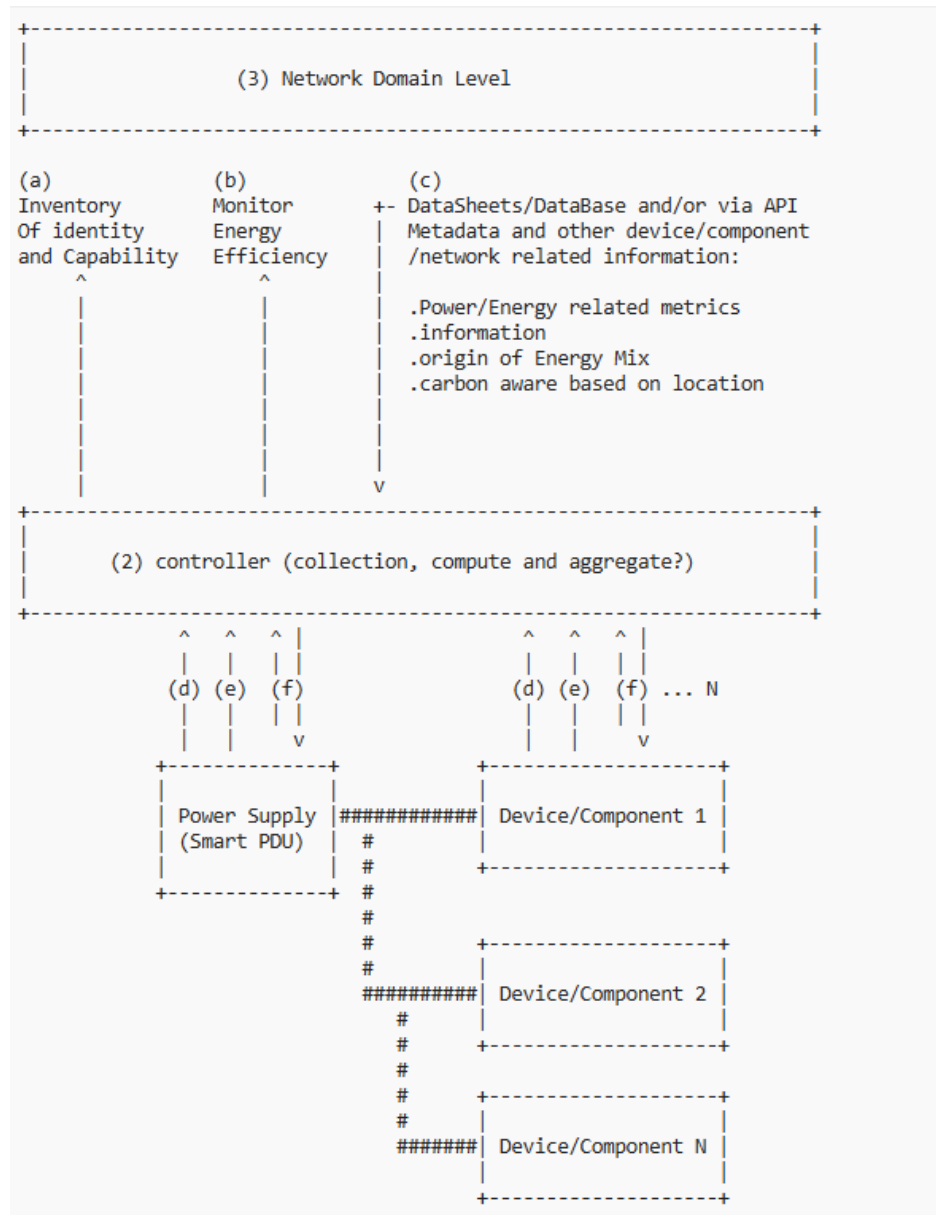
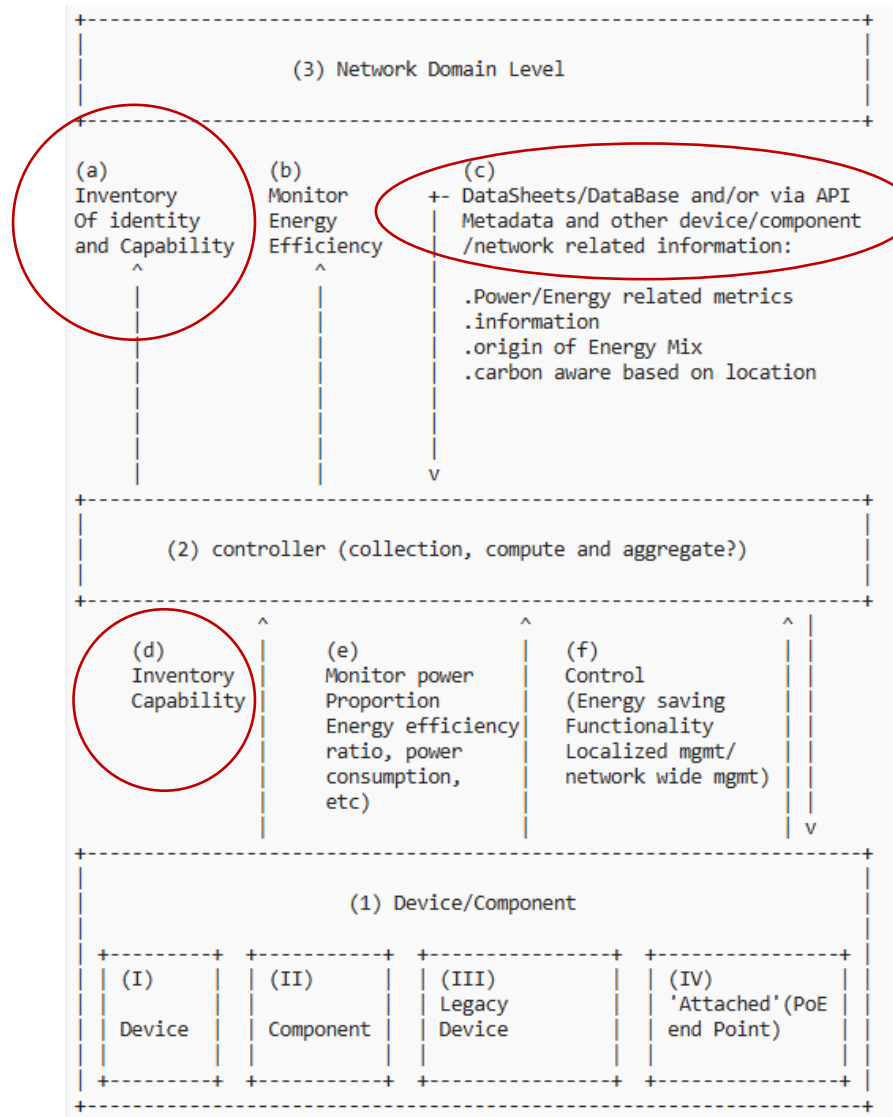

Figure 5: Reference Model Example: Single Power Supply with Multiple Devices

NOTE: "###" is used to denote a transfer of energy.  
 "- >" is used to denote a transfer of information.

# GREEN Reference Model

From the previous interim



## Conclusion:

- Next to the physical topology, we need the power source & control topologies
- **Inventory Capabilities** include metering and power source relationships
- From which interface(s) (a), (c), and/or (d)... to be discussed in the framework document (might vary depending on the lifetime)

# New in draft-belmq-green-framework-03

- \* A Power Source Relationship is a relationship where one Energy Object provides power to one or more Energy Objects. The Power Source Relationship gives a view of the physical wiring topology -- for example, a data center server receiving power from two specific Power Interfaces from two different PDUs.

Note: A Power Source Relationship may or may not change as the direction of power changes between two Energy Objects. The relationship may remain to indicate that the change of power direction was unintended or an error condition.

- \* A Metering Relationship is a relationship where one Energy Object measures power, energy, demand, or Power Attributes of one or more other Energy Objects. The Metering Relationship gives the view of the Metering topology. Physical meters can be placed anywhere in a power distribution tree. For example, utility meters monitor and report accumulated power consumption of the entire building. Logically, the Metering topology overlaps with the wiring topology, as meters are connected to the wiring topology. A typical example is meters that clamp onto the existing wiring.

# New in draft-belmq-green-framework-03

## 4.3. Power State Set

The Energy Object contains a Power State Set attribute that represents the set of Power States a device or component supports.

A Power State describes a condition or mode of a device or component. While Power States are typically used for control, they may be used for monitoring only.

A device or component is expected to support at least one set of Power States consisting of at least two states: an on state and an off state.

The semantics of a Power State are specified by:

- \* The functionality provided by an Energy Object in this state.
- \* A limitation of the power that an Energy Object uses in this state.
- \* A combination of the first two.

The semantics of a Power State should be clearly defined. Limitation (curtailment) of the power used by an Energy Object in a state may be specified by:

- \* An absolute power value.
- \* A percentage value of power relative to the Energy Object's Nameplate Power.
- \* An indication of power relative to another Power State. For example, specify that power in state A is less than in state B.
- \* For supporting Power State management, an Energy Object provides statistics on Power States, including the time an Energy Object spent in a certain Power State and the number of times an Energy Object entered a Power State.

There are many existing standards describing device and component Power States. TO BE COMPLETED

# Questions: Power State

- #1. Do we want more than on/off?  
If yes, we need a variable "something"
- If yes #2: finite number of value/state versus a range (let's say 0 to 100)?
  - If finite number of value/state
    - power state is one solution (or energy saving mode)
  - If a range
    - this could be a single value with the range from 0 to 100 (as advocating on the mailing list)  
What is going to be the effect if I want to set it 42 and the component does not understand